

ROTOMECH

CYCLONE 'FLEX'

Rasaerba rotativo combinato
Flex wing grooming mower
Tondeuse combinée "Flex"
Gezogener klappbare Großflächenmäher

▶ Central Frame

▶ Lift Section

▶ Main Gearbox

▶ Main Driveline

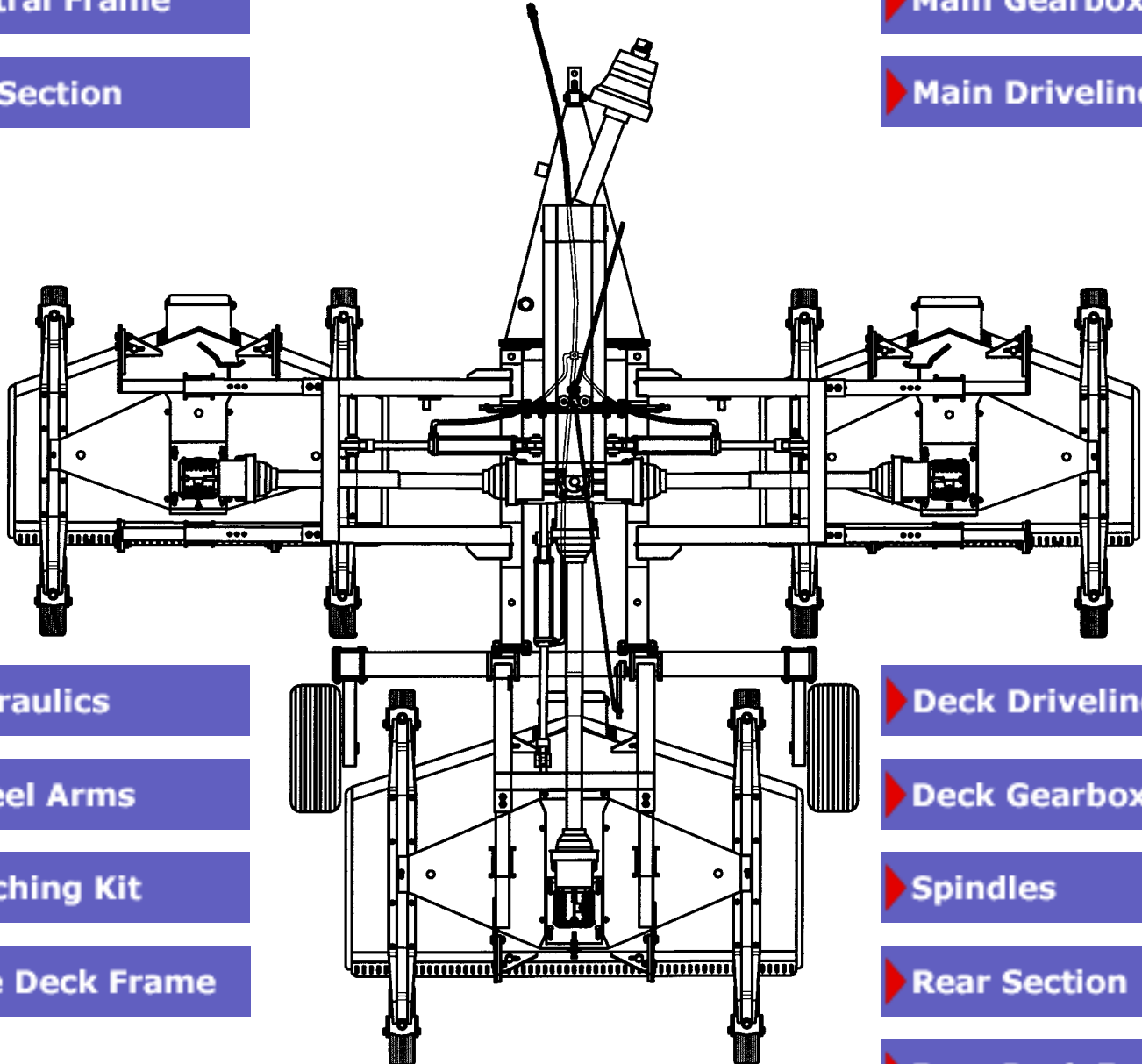

▶ Hydraulics

▶ Wheel Arms

▶ Mulching Kit

▶ Side Deck Frame

▶ Deck Drivelines

▶ Deck Gearboxes

▶ Spindles

▶ Rear Section

▶ Rear Deck Frame

Rotomec: Cyclone 'Flex' Pre 06/2007

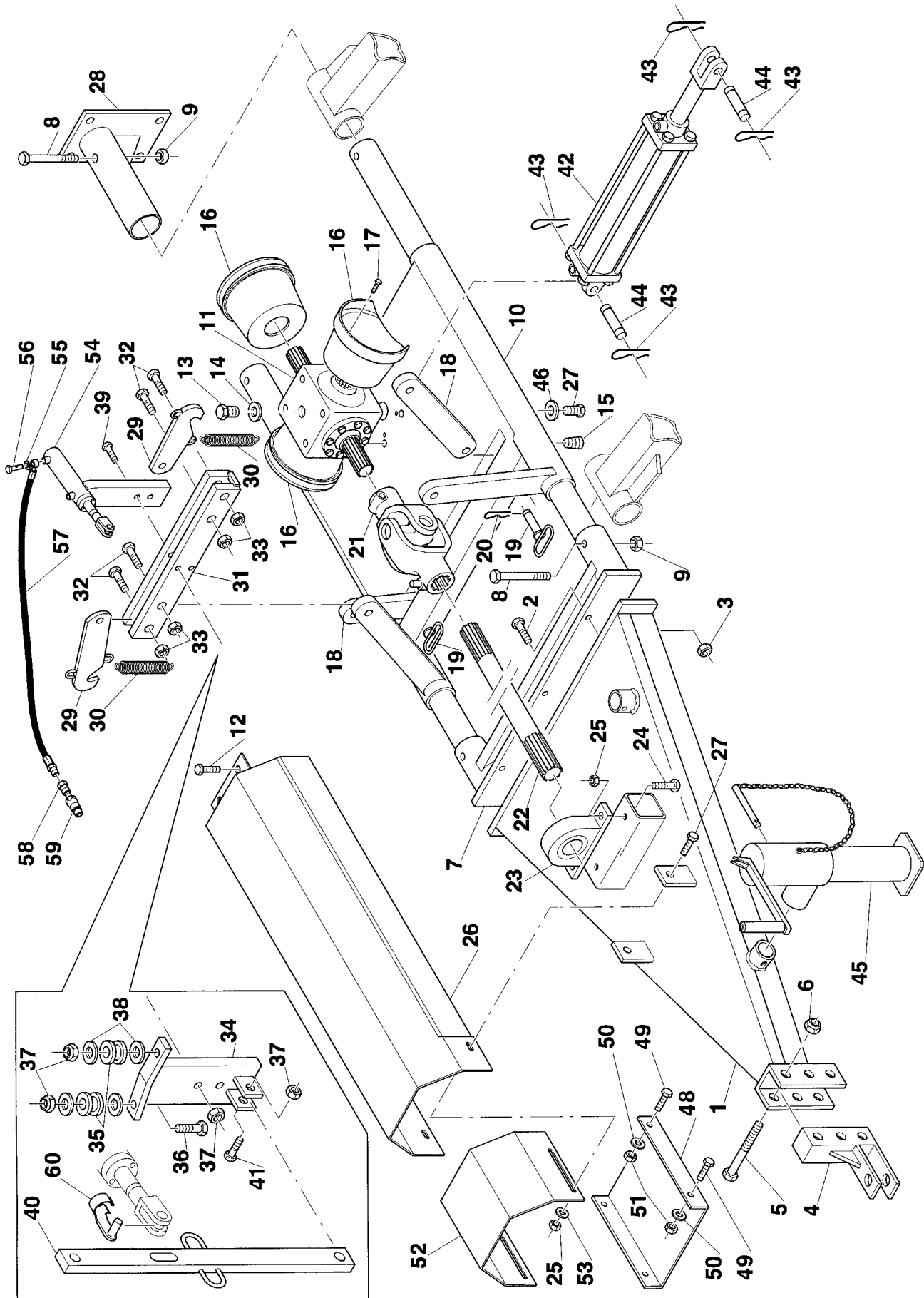

Rotomec: Cyclone 'Flex' Pre 06/2007

N.	COD.	DESCRIZIONE	DESCRIPTION	DESCRIPTION	BESCHREIBUNG	N.
1	0058011	Timone	Draw bar	Timon	Deichsel	1
	0058022	Timone-10/00	Draw bar-10/00	Timon-10/00	Deichsel-10/00	1
2	0064377	Vite TE 18x45	Bolt TE 18x45	Vis TE 18x45	Schraube TE 18x45	6
3	0017506	Dado D.18	Nut D.18	Ecrou D.18	Mutter D.18	6
4	0058031	Attacco anteriore	Front hitch	Attelage antérieur	Vorderanschluß	1
	0058041	Attacco anteriore girevole	Turning tractor linkage	Attelage pivotant pour tracteur	Drehbarer Schlepperanschluß	1
	0058050	Attacco anteriore oscillante	Front floating hitch	Attelage oscillant antérieur	Pendelnder Vorderanschluß	1
5	0037368	Vite TE 14x120	Bolt TE 14x120	Vis TE 14x120	Schraube TE 14x120	3
6	0030358	Dado D.14	Nut D.14	Ecrou D.14	Mutter D.14	3
7	0009612	Attacco telaio centrale	Central frame hitch	Attelage châssis central	Zentralrahmenanschluß	1
	0058028	Attacco telaio centrale-10/00	Central frame hitch-10/00	Attelage châssis central-10/00	Zentralrahmenanschluß-10/00	1
8	0006480	Vite TE 14x100	Bolt TE 14x100	Vis TE 14x100	Schraube TE 14x100	4
9	0001103	Dado D.14	Nut D.14	Ecrou D.14	Mutter D.14	4
10	0058100	Telaio centrale	Main frame	Châssis central	Zentralrahmen	1
11	0500617	Gruppo scatola	Gearbox	Boîtier	Gehäusegruppe	1
12	0064648	Vite TE 12x20	Bolt TE 12x20	Vis TE 12x20	Schraube TE 12x20	
13	0001106	Sfiatatoio	Breather cap	Bouchon d'huile	Gehäuseentlüfter	1
14	0006691	Guarnizione	Gasket	Joint d'étanchéité	Dichtung	2
15	0053446	Tappo	Cap	Bouchon d'huile	Deckel	1
16	0008663	Protezione cardano	Shaft protection	Protection arbre	Kardangelenschutz	3
17	0006349	Vite TE 10x20	Bolt TE 10x20	Vis TE 10x20	Schraube TE 10x20	12
18	0009173	Piastra di attacco	Hitch plate	Plaque d'attache	Anschlußplatte	
19	0009201	Tondo per spina	Pin	Cheville	Stiftrundeisen	2
20	0091507	Copiglia a molla D.4	Cotter pin D.4	Goupille ressort D.4	Federsplint D.4	2
21	0009264	Snodo	Joint	Joint	Gelenk	2
22	0009590	Albero P.D.F.	Input shaft	Arbre P.D.F.	Zapfwelle	1
23	0009223	Supporto SAP 207	Pillow block bearing SAP 207	Soutien SAP 207	Support SAP 207	1
24	0023265	Vite TE 12x40	Bolt TE 12x40	Vis TE 12x40	Schraube TE 12x40	2
25	0094139	Dado D.12	Nut D.12	Ecrou D.12	Mutter D.12	4
26	0009701	Protezione albero P.D.F.	Shaft protection	Protection arbre P.D.F.	Zapfwellenschutz	1
27	0015255	Vite TE 12x30	Bolt TE 12x30	Vis TE 12x30	Schraube TE 12x30	2
28	0158111	Attacco telaio posteriore dx	Rear right hitch	Attelage châssis arrière droit	Rechter Hinterrahmenanschluß	1
	0258111	Attacco telaio posteriore sx	Rear left hitch	Attelage châssis arrière gauche	Linker Hinterrahmenanschluß	1
29	0009721	Piastra di aggancio	Transport hook	Plaque d'accrochage	Verbindungsplatte	3
30	0008586	Molla	Spring	Ressort	Feder	3
31	0009711	Attacco ganci laterali	Hook support plate	Plaque d'accrochage	Seitenhakenanschluß	1
32	0033218	Vite TE 16x55	Bolt TE 16x55	Vis TE 16x55	Schraube TE 16x55	4
33	0005581	Dado D.16	Nut D.16	Ecrou D.16	Mutter D.16	4
34	0009731	Supporto leva di comando	Rope guide bracket	Soutien de commandes	Steuerhebelstütze	1
35	0009476	Puleggia nylon	Pulley	Poulie	Scheibe	2
36	0030331	Vite TE 10x50	Bolt TE 10x50	Vis TE 10x50	Schraube TE 10x50	2

Rotomec: Cyclone 'Flex' Pre 06/2007

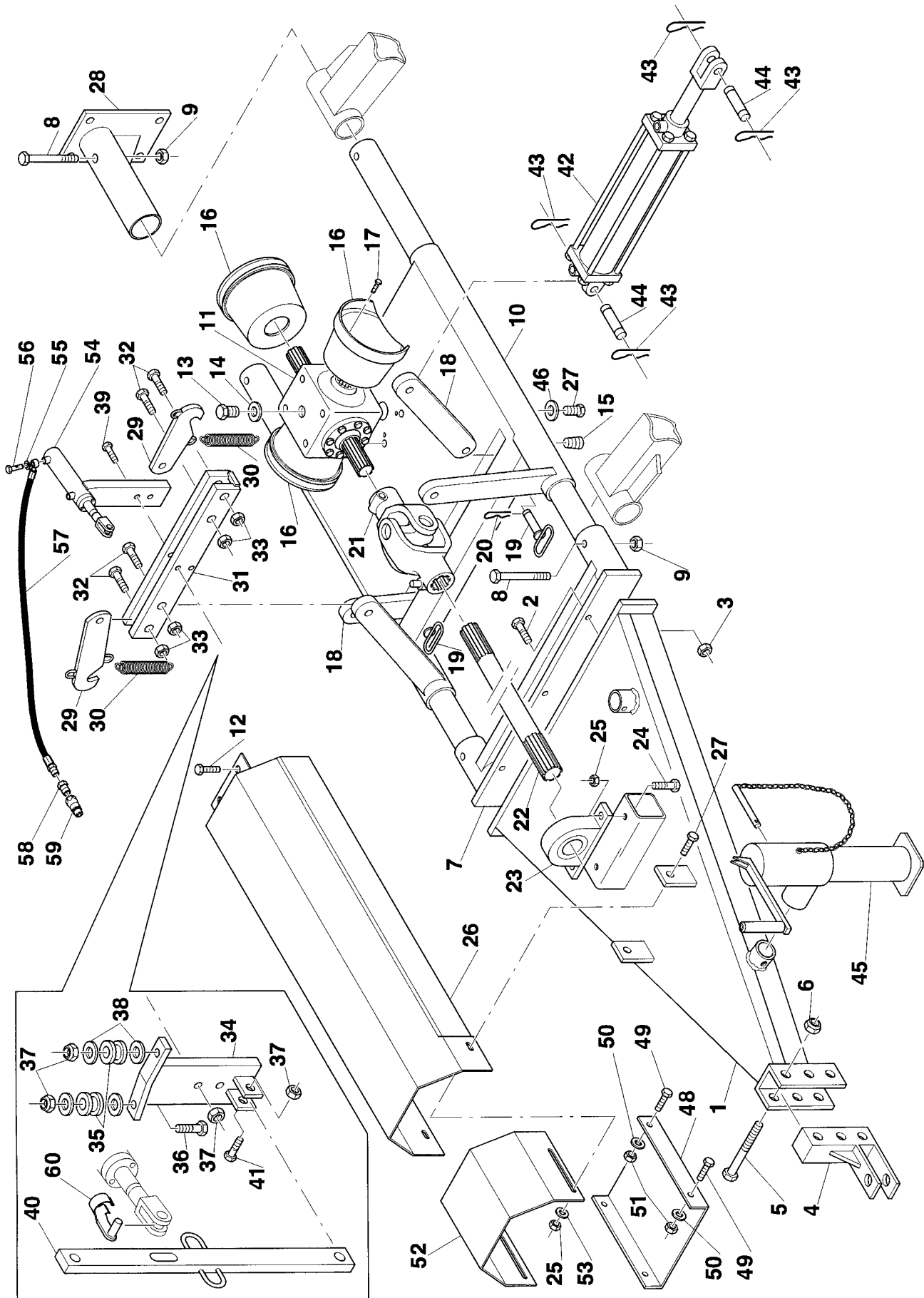

Rotomec: Cyclone 'Flex' Pre 06/2007

N.	COD.	DESCRIZIONE	DESCRIPTION	DESCRIPTION	BESCHREIBUNG	N.
37	0030156	Dado D.10	Nut D.10	Ecrou D.10	Mutter D.10	5
38	0002034	Rondella piana D.10	Flat washer D.10	Rondelle plate D.10	Flache Scheibe D.10	4
39	0130155	Vite TE 10x60	Bolt TE 10x60	Vis TE 10x60	Schraube TE 10x60	2
40	0009737	Leva di comando	Unlocking handle	Levier de réglage	Steuerhebel	1
41	0038614	Vite TE 10x40	Bolt TE 10x40	Vis TE 10x40	Schraube TE 10x40	1
42	503-034B	Martinetto	Hydraulic cylinder	Vérin	Winde	3
43	501-172B	Copiglia	Cotter pin	Goupille	Splint	12
44	501-171B	Perno	Pin	Axe	Stift	6
45	502-098B	Piedino di appoggio	Stand	Pied de soutien	Stutzfuss	1
46	0001077	Rosetta elastica D.12	Spring washer D.12	Rondelle élastique D.12	Sprenging D.12	4
47	0006647	Tappo	Cap	Bouchon d'huile	Deckel	2
48	0009703	Protezione inferiore	Bottom shield	Protection inférieure	Unterer Schutz	1
49	0046454	Vite TE 8x16	Bolt TE 8x16	Vis TE 8x16	Schraube TE 8x16	4
50	0003144	Rosetta elastica D.8	Spring washer D.8	Rondelle élastique D.8	Sprenging D.8	4
51	0001806	Dado D.8	Nut D.8	Ecrou D.8	Mutter D.8	4
52	0009702	Protezione scorrevole P.D.F.	Sliding input shaft protection	Protection arbre coulissante	Gleitender Kardangelenschutz	1
53	0076106	Rondella piana D.12	Flat washer D.12	Rondelle plate D.12	Flache Scheibe D.12	4
54	0023962	Martinetto	Hydraulic cylinder	Vérin	Winde	1
55	0057114	Rondella in rame	Copper washer	Rondelle de cuivre	Kupferscheibe	1
56	0057113	Vite forata	Benjo bolt	Vis trouée	Schraube mit Bohrung	1
57	0057111	Tubo anteriore	Front tube	Tube antérieur	Vorderes Rohr	1
58	0041873	Niples di giunzione	Nipple	Raccord	Anschlußnippel	1
59	0041871	Innesto rapido	Quick connector	Branchement rapide	Rasches Einschalten	1
60	0023964	Perno fissa martinetto	Jack fixing pin	Pivot fixe vérin	Wagenheberfixierungstift	1

Rotomec: Cyclone 'Flex'

Post June 2007

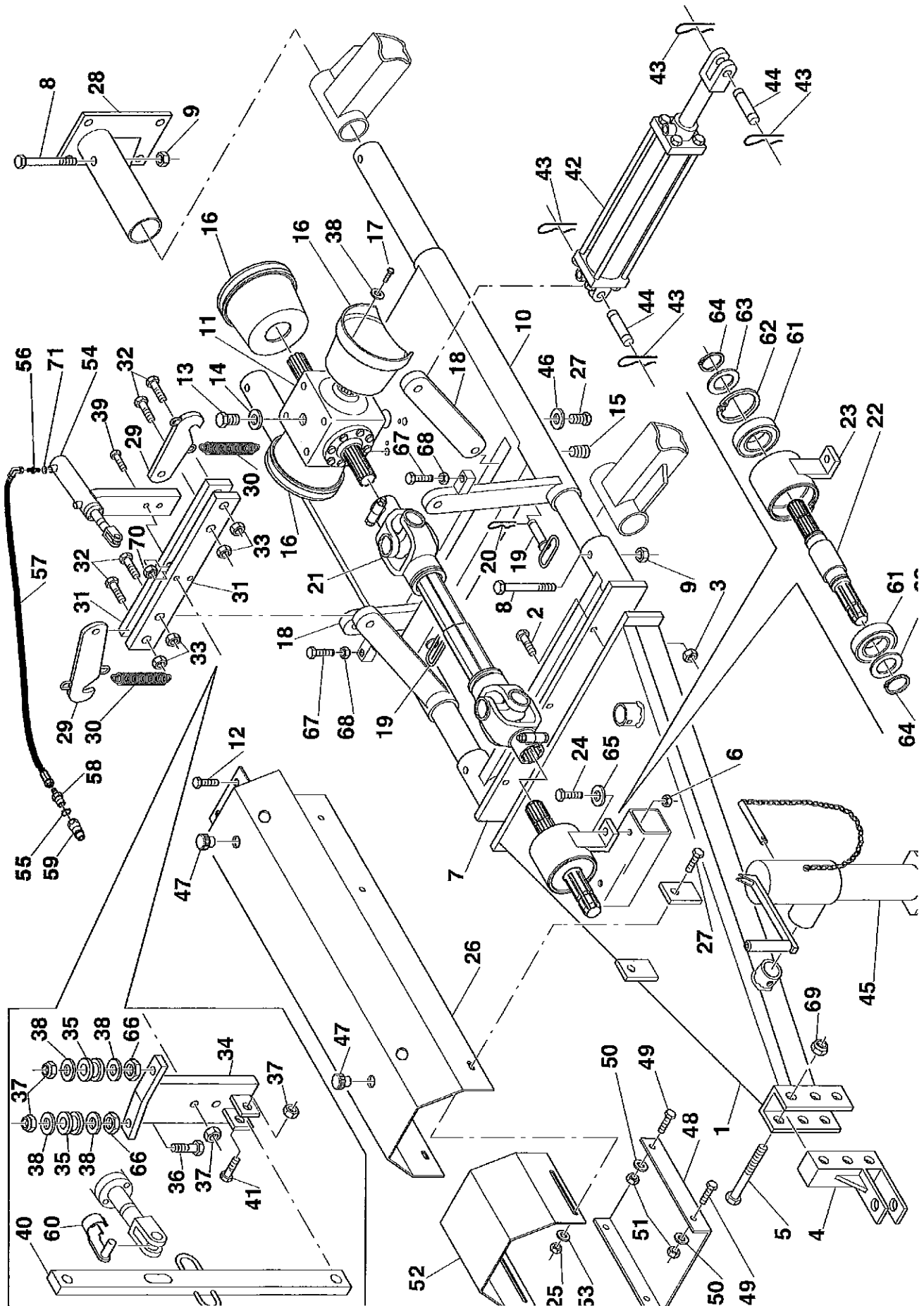

Rotomec: Cyclone 'Flex'

Post June 2007

N.	COD.	DESCRIZIONE	DESCRIPTION	DESCRIPTION	BESCHREIBUNG	N.
1	0058011	Timone	Draw bar	Timon	Deichsel	1
	0058022	Timone-10/00	Draw bar-10/00	Timon-10/00	Deichsel-10/00	1
2	0064377	Vite TE 18x45	Bolt TE 18x45	Vis TE 18x45	Schraube TE 18x45	8
3	0017506	Dado D.18	Nut D.18	Ecrou D.18	Mutter D.18	8
4	0058031	Attacco anteriore	Front hitch	Attelage antérieur	Vorderanschluß	1
	0058041	Attacco anteriore girevole	Turning tractor linkage	Attelage pivotant pour tracteur	Drehbarer Schlepperanschluß	1
	0058050	Attacco anteriore oscillante	Front floating hitch	Attelage oscillant antérieur	Pendelnder Vorderanschluß	1
5	0037368	Vite TE 14x120	Bolt TE 14x120	Vis TE 14x120	Schraube TE 14x120	3
6	0030358	Dado D.14	Nut D.14	Ecrou D.14	Mutter D.14	2
7	0009612	Attacco telaio centrale	Central frame hitch	Attelage châssis central	Zentralrahmenanschluß	1
	0058028	Attacco telaio centrale-10/00	Central frame hitch-10/00	Attelage châssis central-10/00	Zentralrahmenanschluß-10/00	1
8	0006480	Vite TE 14x100	Bolt TE 14x100	Vis TE 14x100	Schraube TE 14x100	4
9	0001103	Dado D.14	Nut D.14	Ecrou D.14	Mutter D.14	4
10	0058100	Telaio centrale	Main frame	Châssis central	Zentralrahmen	1
11	0500617	Gruppo scatola	Gearbox	Boîtier	Gehäusegruppe	1
12	0064648	Vite TE 12x20	Bolt TE 12x20	Vis TE 12x20	Schraube TE 12x20	2
13	0001107A	Sfiatatoio	Breather cap	Bouchon d'huile	Gehäuseentlüfter	1
14	0006691	Guarnizione	Gasket	Joint d'étanchéité	Dichtung	1
15	0053446	Tappo	Cap	Bouchon d'huile	Deckel	1
16	0008663	Protezione cardano	Shaft protection	Protection arbre	Kardangelenkschutz	3
17	0006349	Vite TE 10x20	Bolt TE 10x20	Vis TE 10x20	Schraube TE 10x20	12
18	0009173	Piastra di attacco	Hitch plate	Plaque d'attache	Anschlußplatte	2
19	0009201	Spina	Pin	Cheville	Stiftrundeisen	2
20	0091507	Copiglia a molla D.4	Cotter pin D.4	Goupille ressort D.4	Federsplint D.4	2
21	0009264	Snodo	Joint	Joint	Gelenk	2
	0500485	Cardano da 06/2007	PTO shaft since 06/2007	Arbre à cardan depuis 06/2007	Kardangelenk ab 06/2007	1
22	0009590	Albero P.D.F.	Input shaft	Arbre P.D.F.	Zapfwelle	1
	0027366	Albero P.D.F. da 06/2007	Input shaft since 06/2007	Arbre P.D.F. depuis 06/2007	Zapfwelle ab 06/2007	1
23	0009223	Supporto SAP 207	Pillow block bearing SAP 207	Soutien SAP 207	Support SAP 207	1
	0027360	Supporto da 06/2007	Pillow block bearing since 06/2007	Soutien depuis 06/2007	Support ab 06/2007	1
24	0023265	Vite TE 12x40	Bolt TE 12x40	Vis TE 12x40	Schraube TE 12x40	2
	0001526	Vite TE 14x35 da 06/2007	Bolt TE 14x35 since 06/2007	Vis TE 14x35 depuis 06/2007	Schraube TE 14x35 ab 06/2007	2
25	0094139	Dado D.12	Nut D.12	Ecrou D.12	Mutter D.12	2
26	0009701	Protezione albero P.D.F.	Shaft protection	Protection arbre P.D.F.	Zapfwellenschutz	1
	0028210	Protezione albero P.D.F. Da 06/2007	Shaft protection since 06/2007	Protection arbre P.D.F. Depuis 06/2007	Zapfenwellenschutz ab 06/2007	1
27	0015255	Vite TE 12x30	Bolt TE 12x30	Vis TE 12x30	Schraube TE 12x30	6
28	0158111	Attacco telaio posteriore dx	Rear right hitch	Attelage châssis arrière droit	Rechter Hinterrahmenanschluß	1
	0258111	Attacco telaio posteriore sx	Rear left hitch	Attelage châssis arrière gauche	Linker Hinterrahmenanschluß	1
29	0009721	Piastra di aggancio	Transport hook	Plaque d'accrochage	Verbindungsplatte	3
30	0008586	Molla	Spring	Ressort	Feder	3
	0051740	Molla dal 04/07	Spring since 04/07	Ressort dès 04/07	Feder ab 04/07	3

N.	COD.	DESCRIZIONE	DESCRIPTION	DESCRIPTION	BESCHREIBUNG	N.
31	0009711	Attacco ganci laterali	Hook support plate	Plaque d'accrochage	Seitenhakenanschluß	1
	0009712	Attacco ganci laterali dal 11/07	Hook support plate since 11/07	Plaque d'accrochage dès 11/07	Seitenhakenanschluß ab 11/07	2
32	0033218	Vite TE 16x55	Bolt TE 16x55	Vis TE 16x55	Schraube TE 16x55	4
33	0005581	Dado D.16	Nut D.16	Ecrou D.16	Mutter D.16	4
34	0009731	Supporto leva di comando	Rope guide bracket	Soutien de commandes	Steuerhebelstütze	1
35	0009476	Puleggia nylon	Pulley	Poulie	Scheibe	2
36	0030334	Vite TE 10x55	Bolt TE 10x55	Vis TE 10x55	Schraube TE 10x55	2
37	0030156	Dado D.10	Nut D.10	Ecrou D.10	Mutter D.10	5
38	0002034	Rondella piana D.10	Flat washer D.10	Rondelle plate D.10	Flache Scheibe D.10	16
39	0032619	Vite TE 10x65	Bolt TE 10x65	Vis TE 10x65	Schraube TE 10x65	2
40	0009737	Leva di comando	Unlocking handle	Levier de réglage	Steuerhebel	1
	0009740	Leva di comando per martinetto di sblocco	Jack unlocking handle	Levier de réglage pour le vérin de déblocage	Steuerhebel für Winde	1
41	0038614	Vite TE 10x40	Bolt TE 10x40	Vis TE 10x40	Schraube TE 10x40	1
42	503-034B	Martinetto	Hydraulic cylinder	Vérin	Winde	3
43	502-172B	Copiglia	Cotter pin	Goupille	Splint	12
44	502-171B	Perno	Pin	Axe	Stift	6
45	502-098B	Piedino di appoggio	Stand	Pied de soutien	Stutzfuss	1
46	0001077	Rosetta elastica D.12	Spring washer D.12	Rondelle élastique D.12	Sprengring D.12	4
47	0006647	Tappo	Cap	Bouchon d'huile	Deckel	6
48	0009703	Protezione inferiore	Bottom shield	Protection inférieure	Unterer Schutz	1
49	0046454	Vite TE 8x16	Bolt TE 8x16	Vis TE 8x16	Schraube TE 8x16	4
50	0003144	Rosetta elastica D.8	Spring washer D.8	Rondelle élastique D.8	Sprengring D.8	4
51	0001806	Dado D.8	Nut D.8	Ecrou D.8	Mutter D.8	4
52	0009702	Protezione scorrevole P.D.F.	Sliding input shaft protection	Protection arbre coulissante	Gleitender Kardangelenschutz	1
53	0076106	Rondella piana D.12	Flat washer D.12	Rondelle plate D.12	Flache Scheibe D.12	4
54	0023962	Martinetto	Hydraulic cylinder	Vérin	Winde	1
55	0036532	Rondella in rame 1/2"	Copper washer 1/2"	Rondelle de cuivre 1/2"	Kupferscheibe 1/2"	1
56	0082484	Niples di giunzione	Nipple	Raccord	Anschlußnippel	1
57	0057111	Tubo anteriore	Front tube	Tube antérieur	Vorderes Rohr	1
58	0082488	Niples di giunzione	Nipple	Raccord	Anschlußnippel	1
59	0041871	Innesto rapido	Quick connector	Branchement rapide	Rasches Einschalten	1
60	0023964	Perno fissa martinetto	Jack fixing pin	Pivot fixe vérin	Wagenheberfixierungstift	1
61	0055358A	Cuscinetto 6208-2RS	Bearing 6208-2RS	Roulement 6208-2RS	Lager 6208-2RS	2
62	0001154	Seeger interno D.80	Inner snap ring D.80	Circlip interne D.80	Innenseegerring D.80	1
63	0053248	Anello di spessoramento	Spacer washer	Anneau d'épaisseur	Distanzring	2
64	0008138	Seeger esterno D.40	Outer snap ring D.40	Circlip externe D.40	Außenseegerring D.40	2
65	0091435	Rondella piana D.14	Flat washer D.14	Rondelle plate D.14	Flache Scheibe D.14	2
66	0001279	Dado D.10	Nut D.10	Ecrou D.10	Mutter D.10	2
67	0023265	Vite TE 12x40	Bolt TE 12x40	Vis TE 12x40	Schraube TE 12x40	2
68	0001106	Dado D.12	Nut D.12	Ecrou D.12	Mutter D.12	2
69	0007224	Dado D.14	Nut D.14	Ecrou D.14	Mutter D.14	3
70	0002366	Dado D.16	Nut D.16	Ecrou D.16	Mutter D.16	2
71	0052438	Rondella in rame 1/4"	Copper washer 1/4"	Rondelle de cuivre 1/4"	Kupferscheibe 1/4"	1

Rotomec: Cyclone 'Flex'

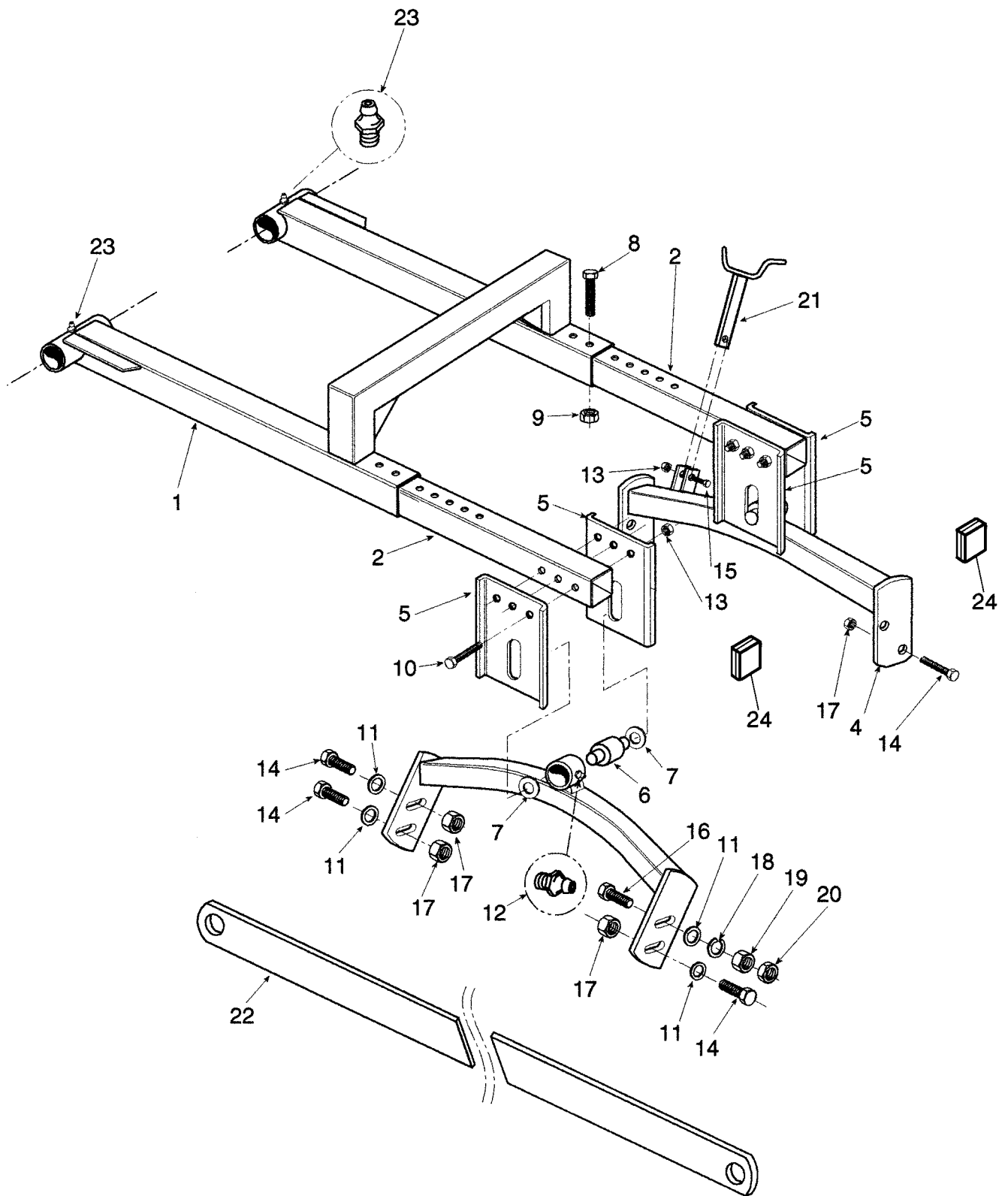

Rotomec: Cyclone 'Flex'

N.	COD.	DESCRIZIONE	DESCRIPTION	DESCRIPTION	BESCHREIBUNG	N.
1	0258080	Sollevamento laterale sx	Left lift side	Soulèvement latéral gauche	Linke Seitenabhebung	1
	0158080	Sollevamento laterale dx	Right lift side	Soulèvement latéral droit	Rechte Seitenabhebung	1
2	0058320	Prolunga laterale v.312-315	Lift arm v.312-315	Prolonge latérale v.312-315	Rechte Seitenverlängerung v.312-315	4
	0058323	Prolunga laterale v.317	Lift arm v.317	Prolonge latérale v.317	Linke Seitenverlängerung v.317	4
3	0058340	Attacco anteriore v.312	Front hitch v.312	Attelage antérieur v.312	Vorderanschluß v.312	2
	0058350	Attacco anteriore v.315	Front hitch v.315	Attelage antérieur v.315	Vorderanschluß v.315	2
	0058360	Attacco anteriore v.317	Front hitch v.317	Attelage antérieur v.317	Vorderanschluß v.317	2
4	0158370	Attacco posteriore dx v.312	Rear right hitch v.312	Attelage postérieur droit v.312	Rechter Hinteranschluß v.312	1
	0258370	Attacco posteriore sx v.312	Rear left hitch v.312	Attelage postérieur gauche v.312	Linker Hinteranschluß v.312	1
	0358370	Attacco posteriore dx v.315-317	Rear right hitch v.315-317	Attelage postérieur droit v.315-317	Rechter Hinteranschluß v.315-317	1
	0458370	Attacco posteriore sx v.315-317	Rear left hitch v.315-317	Attelage postérieur gauche v.315-317	Linker Hinteranschluß v.315-317	1
5	0082176	Piastre di attacco	Hitch plate	Plaque d'attache	Anschlußplatte	8
6	0058333	Perno attacco cycloni	Cyclone hitch pin	Vérin pour attelage Cyclone	Cyclone Anschlußstift	4
7	0003056	Rondella piana D.30	Flat washer D.30	Rondelle plate D.30	Flache Scheibe D.30	8
8	0005536	Vite TE 14x90	Bolt TE 14x90	Vis TE 14x90	Schraube TE 14x90	8
9	0007224	Dado D.14	Nut D.14	Ecrou D.14	Mutter D.14	8
10	0034286	Vite TE 12x100	Bolt TE 12x100	Vis TE 12x100	Schraube TE 12x100	12
11	0008568	Rondella piana D.16	Flat washer D.16	Rondelle plate D.16	Flache Scheibe D.16	8
12	0001065	Ingrassatore	Grease fitting	Graisseur	Schmiernippel	4
13	0030064	Dado D.12	Nut D.12	Ecrou D.12	Mutter D.12	1
14	0002365	Vite TE 16x50	Bolt TE 16x50	Vis TE 16x50	Schraube TE 16x50	14
15	0007716	Vite TE 12x45	Bolt TE 12x45	Vis TE 12x45	Schraube TE 12x45	1
16	0030309	Vite TE 16x70	Bolt TE 16x70	Vis TE 16x70	Schraube TE 16x70	2
17	0005581	Daddo D.16	Nut D.16	Ecrou D.16	Mutter D.16	14
18	0002367	Rosetta elastica D.16	Spring washer D.16	Rondelle élastique D.16	Sprengring D. 16	2
19	0002366	Dado D.16	Nut D.16	Ecrou D.16	Mutter D.16	2
20	0003124	Dado D.16	Nut D.16	Ecrou D.16	Mutter D.16	2
21	0058282	Leva di bloccaggio	Calibration handle	Levier de réglage	Klemmhebel	2
22	0158442	Tirante di sicurezza v.312	Safety tie rod v.312	Tirant de sécurité v.312	Sicherheitszugbolzen v.312	1
	0258442	Tirante di sicurezza v.315	Safety tie rod v.315	Tirant de sécurité v.315	Sicherheitszugbolzen v.315	1
	0358442	Tirante di sicurezza v.317	Safety tie rod v.317	Tirant de sécurité v.317	Sicherheitszugbolzen v.317	1
23	0006635	Ingrassatore	Grease fitting	Graisseur	Schmiernippel	4
24	0058330	Tappo in plastica	Plastic cap	Bouchon d'huile	Deckel	4

Rotomec: Cyclone 'Flex'

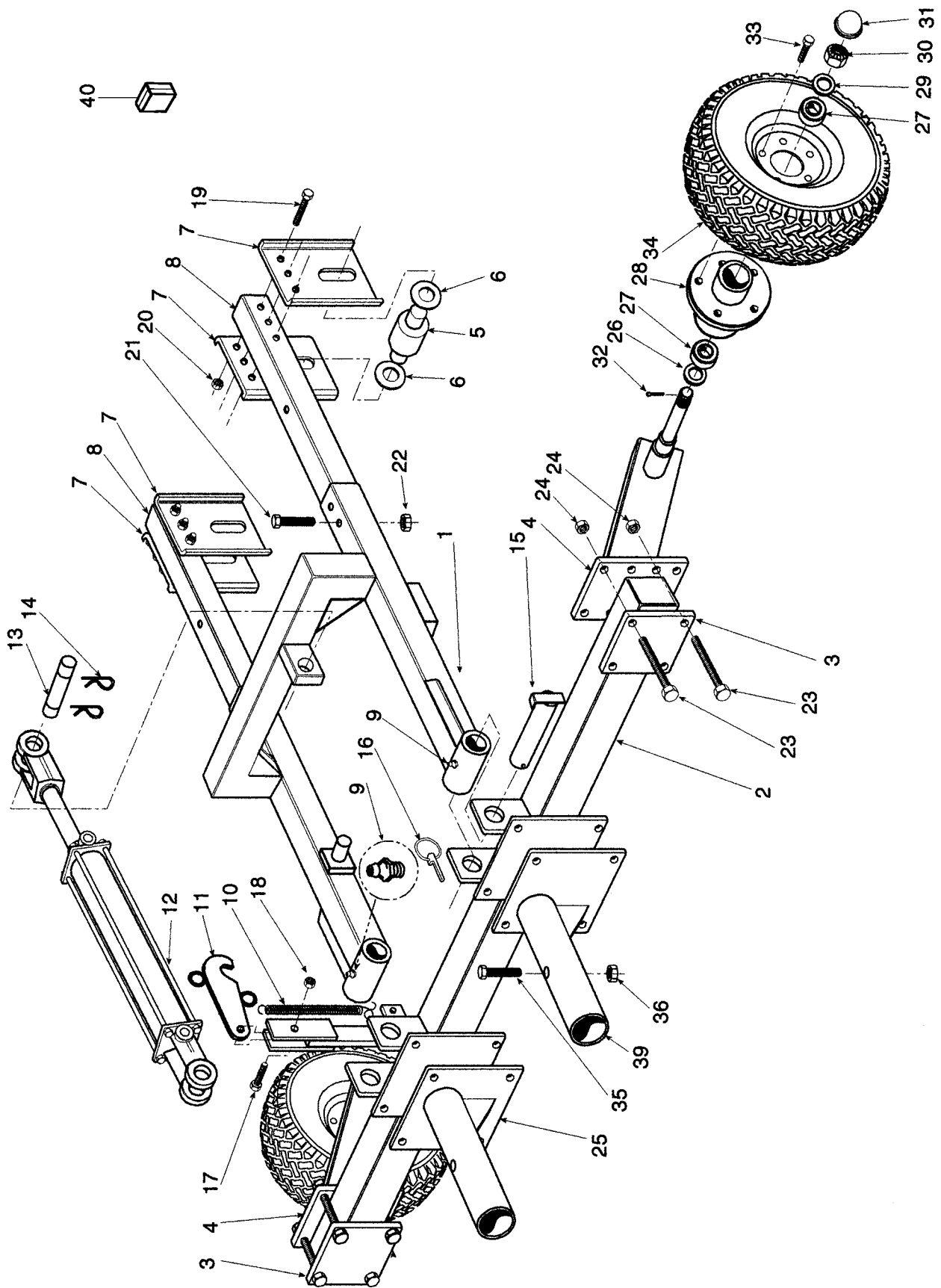

Rotomec: Cyclone 'Flex'

N.	COD.	DESCRIZIONE	DESCRIPTION	DESCRIPTION	BESCHREIBUNG	N.
1	0058290	Sollevamento posteriore	Rear lift	Soulèvement postérieur	Hintere Seitenabhebung	1
2	0058130	Telaio posteriore	Rear frame	Châssis arrière	Hinterer Rahmen	1
3	0009777	Piastra di giunzione	Connector	Plaque de jonction	Verbindungsplatte	2
4	0358230	Supporto ruota destro	Right wheel support	Support roue droit	Rechter Radsupport	1
	0458230	Supporto ruota sinistro	Left wheel support	Support roue gauche	Linker Radsupport	1
5	0058333	Perno attacco cycloni	Cyclone hitch pin	Vérin pour attelage Cyclone	Cyclone Anschlußstift	2
6	0003056	Rondella piana D.30	Flat washer D.30	Rondelle plate D.30	Flache Scheibe D.30	4
7	0082176	Piastre di attacco	Hitch plate	Plaque d'attache	Anschlußplatte	4
8	0058326	Prolunghe posteriori	Rear lift arm	Prolonge lateral postérieur	Hintere Seitenverlängerung	2
9	0001065	Ingrassatore	Grease fitting	Graisseur	Schmiernippel	4
10	0008586	Molla	Spring	Ressort	Feder	1
11	0009721	Piastra di aggancio	Transport hook	Plaque d'accrochage	Verbindungsplatte	1
12	503-034B	Martinetto	Hydraulic cylinder	Vérin	Winde	1
13	501-171B	Perno	Pin	Axe	Stift	2
14	501-172B	Copiglia	Cotter pin	Goupille	Splint	1
15	0058312	Spina per sollevamento posteriore	Rear lifting pin	Cheville pour relevage arrière	Hinterhubstift	2
16	0018266	Copiglia a spina	Lynch pin	Goupille	Klappsplint	2
17	0033218	Vite TE 16x55	Bolt TE 16x55	Vis TE 16x55	Schraube TE 16x55	1
18	0005581	Dado D.16	Nut D.16	Ecrou D.16	Mutter D.16	1
19	0034286	Vita TE 12x100	Bolt TE 12x100	Vis TE 12x100	Schraube TE 12x100	6
20	0030064	Dado D.12	Nut D.12	Ecrou D.12	Mutter D.12	6
21	0005536	Vita TE 14x90	Bolt TE 14x90	Vis TE 14x90	Schraube TE 14x90	2
22	0007224	Dado D.14	Nut D.14	Ecrou D.14	Mutter D.14	3
23	0006615	Vite TE 14x140	Bolt TE 14x140	Vis TE 14x140	Schraube TE 14x140	8
24	0030358	Dado D.14	Nut D.14	Ecrou D.14	Mutter D.14	2
25	0158111	Attacco telaio posteriore dx	Rear right hitch	Attelage châssis arrière droit	Rechter Hinterrahmenanschluß	1
26	0013705	Paraolio 35.52.10	Oil seal 35.52.10	Pare-huile 35.52.10	Simmering 35.52.10	4
27	0009771	Cuscinetto 30205	Bearing 30205	Roulement 30205	Lager 30205	4
28	0009770	Mozzo ruota	Hub wheel	Moyeu roue	Radnabe	2
29	0046555	Rondella piana D.20	Flat washer D.20	Rondelle plate D.20	Flache Scheibe D.20	2
30	0009768	Dado D.20	Nut D.20	Ecrou D.20	Mutter D.20	2
31	0009769	Coperchiella ruotina	Wheel cover	Couvercle roue	Rädchenhaube	2
32	0044156	Copiglia D.4x25	Cotter pin D.4x25	Goupille D.4x25	Splint D.4x25	2
33	503-486B	Vite fissa mozzo	Hub bolt	Vis de fixation moyeu	Nabebefestigungsschraube	10
34	190-2063	Ruota	Wheel	Roue	Rad	2
35	0006480	Vite TE 14x100	Bolt TE 14x100	Vis TE 14x100	Schraube TE 14x100	2
36	0001103	Dado D.14	Nut D.14	Ecrou D.14	Mutter D.14	2
37	0064377	Vite TE 18x45	Bolt TE 18x45	Vis TE 18x45	Schraube TE 18x45	8
38	0017506	Dado D.18	Nut D.18	Ecrou D.18	Mutter D.18	8
39	0258111	Attacco telaio posteriore sx	Rear left hitch	Attelage châssis arrière gauche	Linker Hinterrahmenanschluß	1
40	0058330	Tappo in plastica	Plastic cap	Bouchon d'huile	Deckel	2

Rotomec: Cyclone 'Flex'

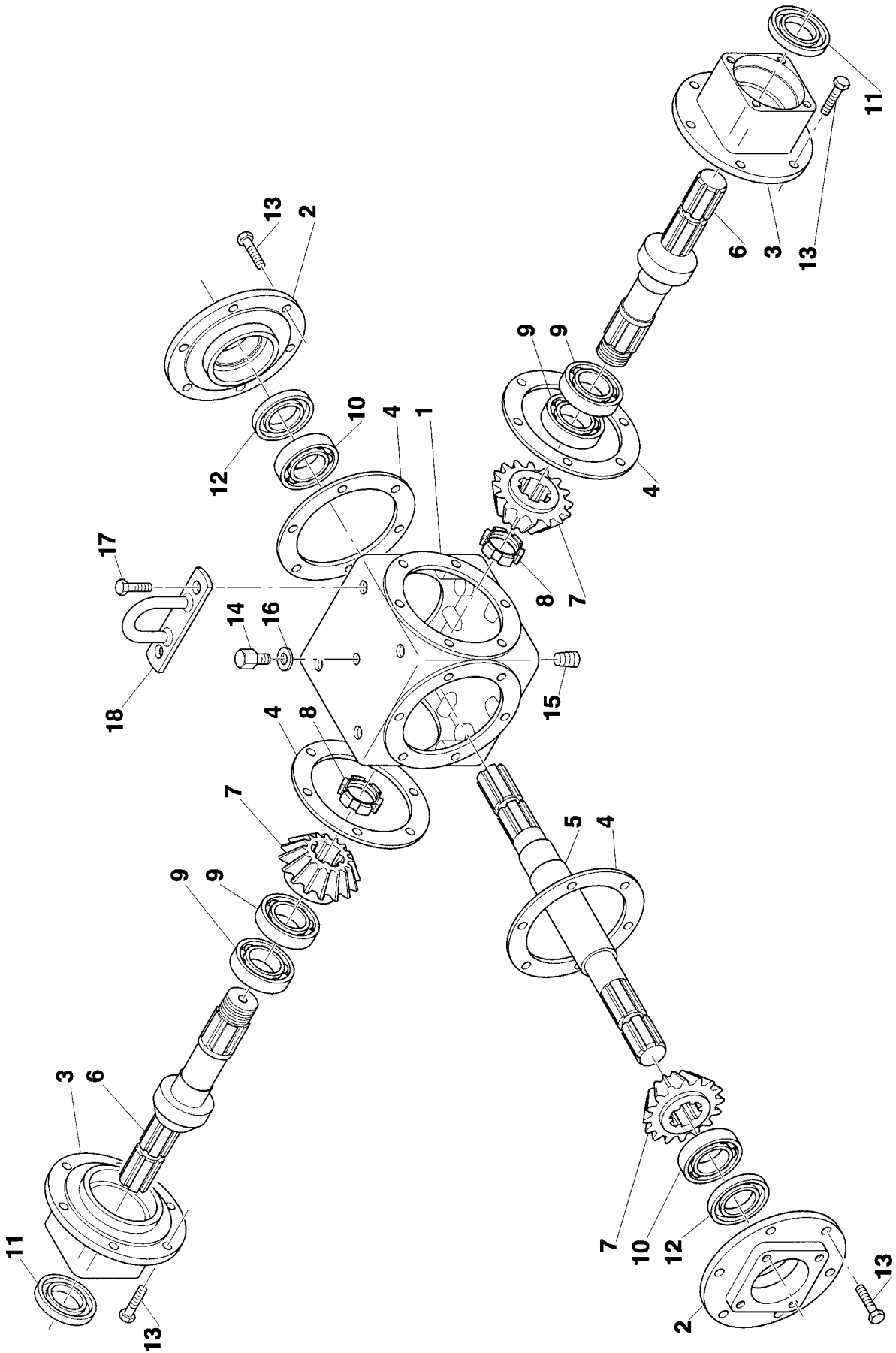

Rotomec: Cyclone 'Flex'

N.	COD.	DESCRIZIONE	DESCRIPTION	DESCRIPTION	BESCHREIBUNG	N.
1	0009970	Scatola ingranaggi	Gearbox	Boîtier	Getriebekasten	1
2	0009971	Coperchiella anteriore	Front cover	Couvercle antérieur	Vorderdeckel	2
3	0009972	Supporto laterale	Lateral support	Soutien latéral	Seitliches Lager	2
4	0030193	Guarnizione	Gasket	Joint d'étanchéité	Dichtung	
	0130193	Guarnizione	Gasket	Joint d'étanchéité	Dichtung	
5	0009975	Albero P.D.F.	Input shaft	Arbre P.D.F.	Zapfwelle	1
6	0009976	Albero P.D.F.	Input shaft	Arbre P.D.F.	Zapfwelle	2
7	0009973	Corona conica	Ring gear	Couronne conique	Tellerrad	3
8	0037098	Ghiera D.35x1,5	Safety nut D.35x1,5	Frette D.35x1,5	Nutmutter D.35x1,5	2
9	0030201	Cuscinetto 30208	Bearing 30208	Roulement 30208	Lager 30208	4
10	0007172	Cuscinetto 30207	Bearing 30207	Roulement 30207	Lager 30207	2
11	0007094	Paraolio 52.85.10	Oil seal 52.85.10	Pare-huile 52.85.10	Simmering 52.85.10	2
12	0009974	Paraolio 35.55.10	Oil seal 35.55.10	Pare-huile 35.55.10	Simmering 35.55.10	2
13	0001241	Vite TE 10x25	Bolt TE 10x25	Vis TE 10x25	Schraube TE 10x25	24
14	0001107	Sfiatatoio	Breather cap	Bouchon d'huile	Gehäuseentlüfter	1
15	0053446	Tappo	Cap	Bouchon d'huile	Deckel	1
16	0006691	Guarnizione	Gasket	Joint d'étanchéité	Dichtung	2
17	0003037	Vite TE 12x25	Bolt TE 12x25	Vis TE 12x25	Schraube TE 12x25	2
18	0023973	Attacco per sollevamento	Lifting hitch	Attelage pour relevage	Hubanschluß	1
	0500617	Gruppo scatola	Gearbox	Boîtier	Gehäusegruppe	

Rotomec: Cyclone 'Flex'

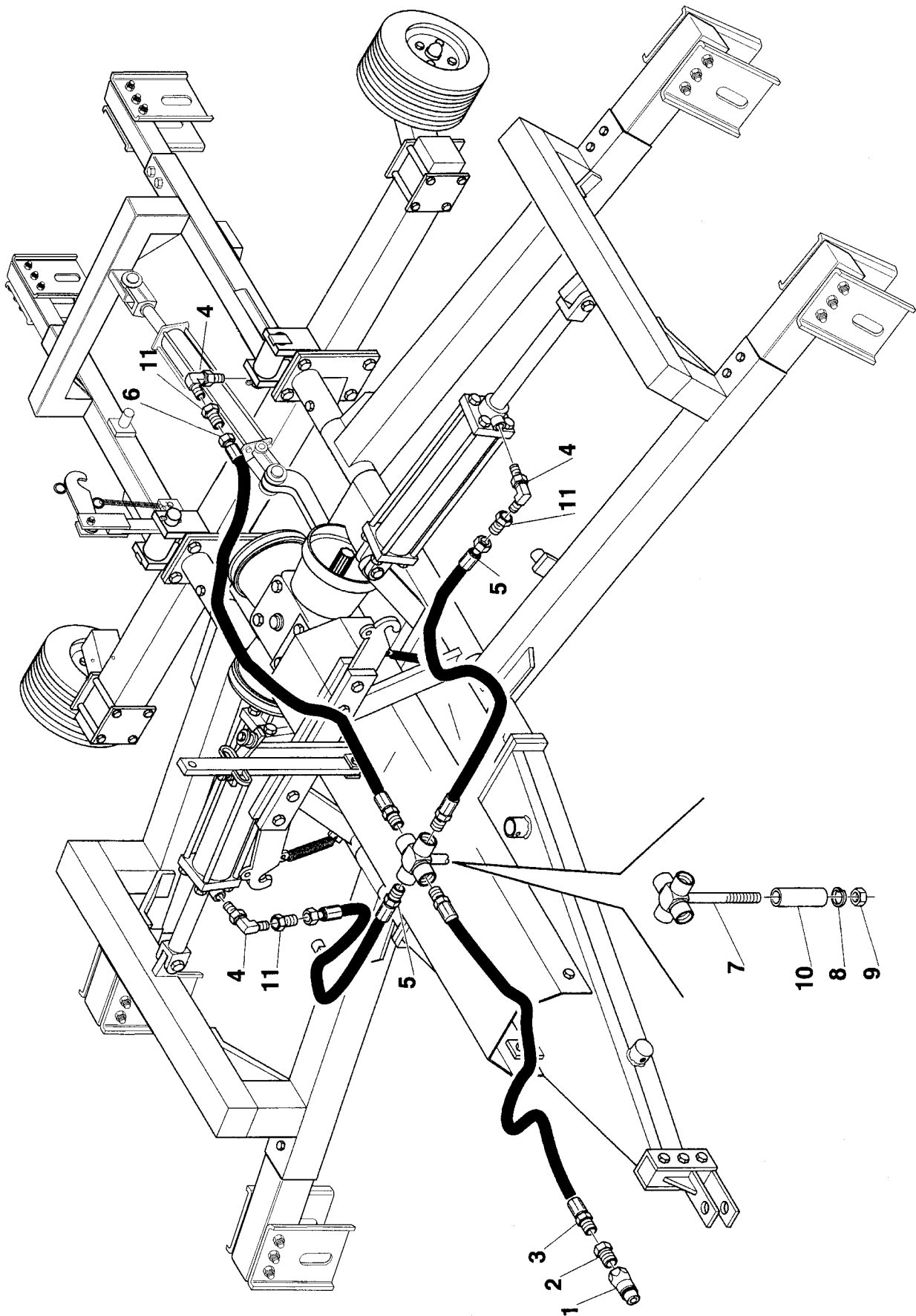

Rotomec: Cyclone 'Flex'

N.	COD.	DESCRIZIONE	DESCRIPTION	DESCRIPTION	BESCHREIBUNG	N.
1	502-170B	Innesto rapido	Quick connector	Branchement rapide	Rasches Einschalten	1
2	502-169B	Raccordo	Connector	Raccord	Anschlußstück	1
3	502-166B	Tubo anteriore	Front tube	Tube antérieur	Vorderes Rohr	1
4	502-163B	Raccordo a 90°	90° Connection	Raccord à 90°	Anschlußstück 90°	3
5	502-168B	Tubo laterale	Lateral tube	Tube latéral	Seitliches Rohr	2
6	502-167B	Tubo posteriore	Rear tube	Tube postérieur	Hinteres Rohr	1
7	502-165B	Raccordo centrale	Central connection	Raccord central	Zentrales Anschlußstück	1
8	0001077	Rosetta elastica D.12	Spring washer D.12	Rondelle élastique D.12	Sprengring D.12	1
9	0003038	Dado D.12	Nut D.12	Ecrou D.12	Mutter D.12	1
10	0021285	Distanziale	Spacer	Entretoise	Distanzstück	1
11	502-164B	Niples di congiunzione	Nipple	Raccord	Anschlußnippel	3

Rotomec: Cyclone 'Flex'

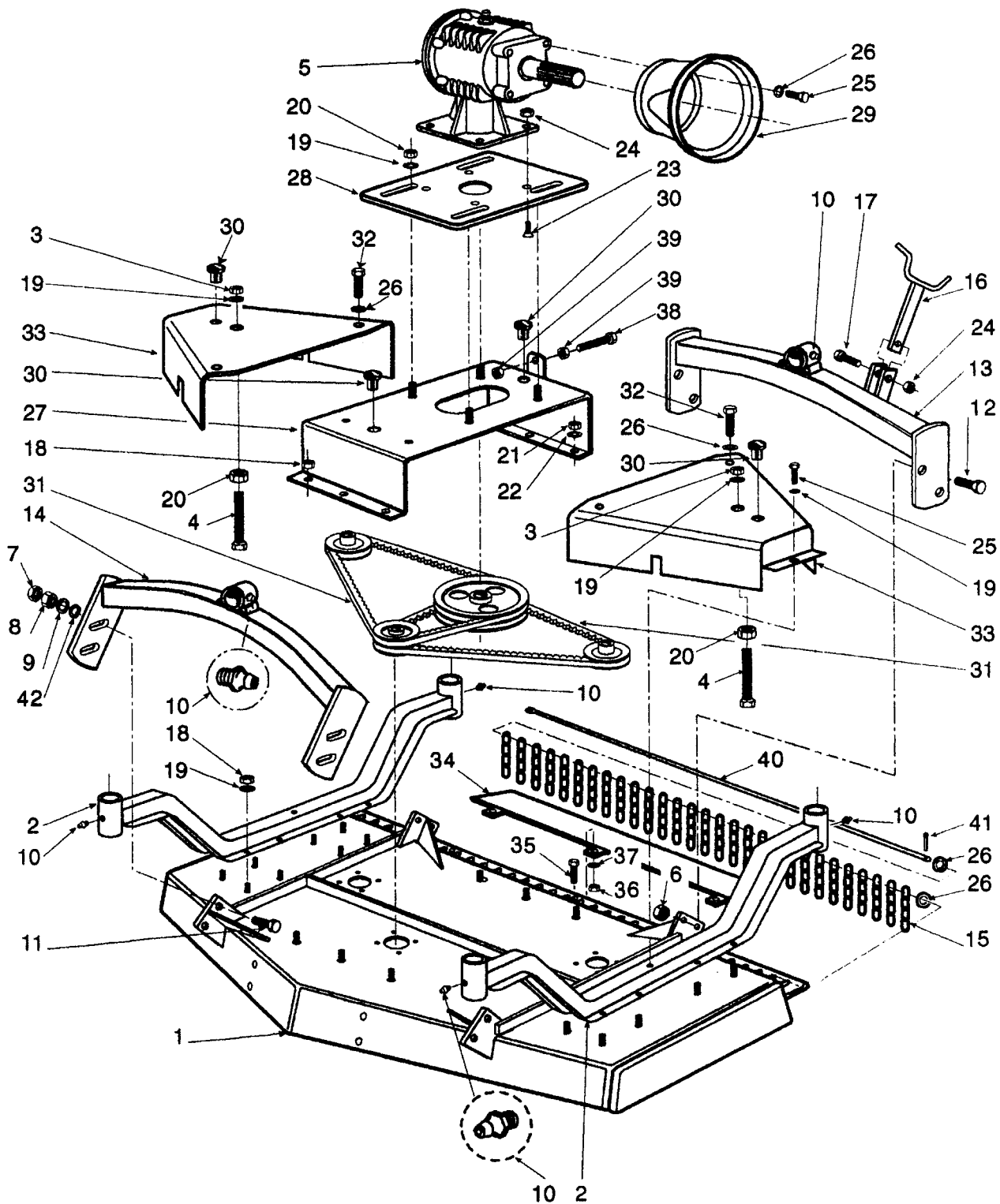

Rotomec: Cyclone 'Flex'

N.	COD.	DESCRIZIONE	DESCRIPTION	DESCRIPTION	BESCHREIBUNG	N.
1	0106903	Telaio v. 312	Frame v. 312	Châssis v. 312	Rahmen v. 312	2
	0206903	Telaio v. 315	Frame v. 315	Châssis v. 315	Rahmen v. 315	2
	0306900	Telaio v. 317	Frame v.317	Châssis v.317	Rahmen v. 317	2
2	0106939	Braccio ruotina v. 312	Wheel arm v. 312	Bras de roue v. 312	Radarm v. 312	4
	0106941	Braccio ruotina v. 312 da 09/00	Wheel arm v. 312 - 09/00	Bras de roue v. 312 - 09/00	Radarm v. 312 - 09/00	
	0206939	Braccio ruotina v. 315	Wheel arm v. 315	Bras de roue v. 315	Radarm v. 315	4
	0206941	Braccio ruotina v. 315 da 09/00	Wheel arm v. 315 - 09/00	Bras de roue v. 315 - 09/00	Radarm v. 315 - 09/00	
	0306932	Braccio ruotina v. 317	Wheel arm v.317	Bras de roue v.317	Radarm v.317	4
	0306941	Braccio ruotina v. 317 da 09/00	Wheel arm v. 317 - 09/00	Bras de roue v. 317 - 09/00	Radarm v.317 - 09/00	
3	0015237	Dado D.10	Nut D.10	Ecrou D.10	Mutter D.10	2
4	0006943	Vite TE 10x120 da 09/00	Bolt TE 10x120 - 09/00	Vis TE 10x120 - 09/00	Schraube TE 10x120 - 09/00	2
5	0500641	Gruppo completo	Complete gearbox	Boîtier complet	Komplette Gehäusegruppe	2
	0500642	Gruppo completo-01/01	Complete gearbox-01/01	Boîtier complet-01/01	Komplette Gehäusegruppe-01/01	2
6	0005581	Dado D.16	Nut D.16	Ecrou D.16	Mutter D.16	14
7	0003124	Dado D.16	Nut D.16	Ecrou D.16	Mutter D.16	1
8	0002366	Dado D.16	Nut D.16	Ecrou D.16	Mutter D.16	1
9	0002367	Rosetta elastica D.16	Spring washer D.16	Rondelle élastique D.16	Sprengring D.16	1
10	0001065	Ingrassatore	Grease fitting	Graisseur	Schmiernippel	5
11	0030309	Vite TE 16x70	Bolt TE 16x70	Vis TE 16x70	Schraube TE 16x70	1
12	0002365	Vite TE 16x50	Bolt TE 16x50	Vis TE 16x50	Schraube TE 16x50	7
13	0158370	Attacco posteriore dx v.312	Rear right hitch v.312	Attelage postérieur droit v.312	Rechter Hinteranschluß v.312	1
	0258370	Attacco posteriore sx v.312	Rear left hitch v.312	Attelage postérieur gauche v.312	Linker Hinteranschluß v.312	1
	0358370	Attacco posteriore dx v.315-317	Rear right hitch v.315-317	Attelage postérieur droit v.315-317	Rechter Hinteranschluß v.315-317	1
	0458370	Attacco posteriore sx v.315-317	Rear left hitch v.315-317	Attelage postérieur gauche v.315-317	Linker Hinteranschluß v.315-317	1
14	0058340	Attacco anteriore v.312	Front hitch v.312	Attelage antérieur v.312	Vorderanschluß v.312	1
	0058350	Attacco anteriore v.315	Front hitch v.315	Attelage antérieur v.315	Vorderanschluß v.315	1
	0058360	Attacco anteriore v.317	Front hitch v.317	Attelage antérieur v.317	Vorderanschluß v.317	1
15	0006764	Catena	Chain	Chaîne	Kette	
16	0058282	Leva di bloccaggio	Kick-out bracket	Levier de réglage	Klemmhebel	2
17	0007716	Vite TE 12x45	Bolt TE 12x45	Vis TE 12x45	Schraube TE 12x45	2
18	0030156	Dado D.10	Nut D.10	Ecrou D.10	Mutter D.10	38
19	0030157	Rondella piana D.10	Flat washer D.10	Rondelle plate D.10	Flache Scheibe D.10	44
20	0014106	Dado autobloccante D.10	Locking nut D.10	Ecrou D.10	Mutter D.10	12
21	0001279	Dado D.10	Nut D.10	Ecrou D.10	Mutter D.10	6
22	0001280	Rosetta elastica D.10	Spring washer D.10	Rondelle élastique D.10	Sprengring D.10	6
23	0074183	Vite TSPEI 12x40	Bolt TSPEI 12x40	Vis TSPEI 12x40	Schraube TSPEI 12x40	8
24	0030064	Dado D.12	Nut D.12	Ecrou D.12	Mutter D.12	10
25	0006349	Vite TE 10x20	Bolt TE 10x20	Vis TE 10x20	Schraube TE 10x20	12
26	0002034	Rondella piana D.10	Flat washer D.10	Rondelle plate D.10	Flache Scheibe D.10	20
27	0006904	Piastra centrale v.312	Central plate v.312	Plaque centrale v.312	Zentrale Platte v.312	2
	0006875	Piastra centrale v.315	Central plate v.315	Plaque centrale v.315	Zentrale Platte v.315	2
	0006913	Piastra centrale v.317	Central plate v.317	Plaque centrale v.317	Zentrale Platte v.317	2
28	0006541	Piastra supporto scatola	Gearbox support plate	Plaque support boîtier	Gehäusestützplatte	2
29	0008663	Protezione cardano	Shaft protection	Protection arbre	Kardangelenschutz	2
30	0006647	Tappo	Cap	Bouchon d'huile	Deckel	8

Rotomec: Cyclone 'Flex'

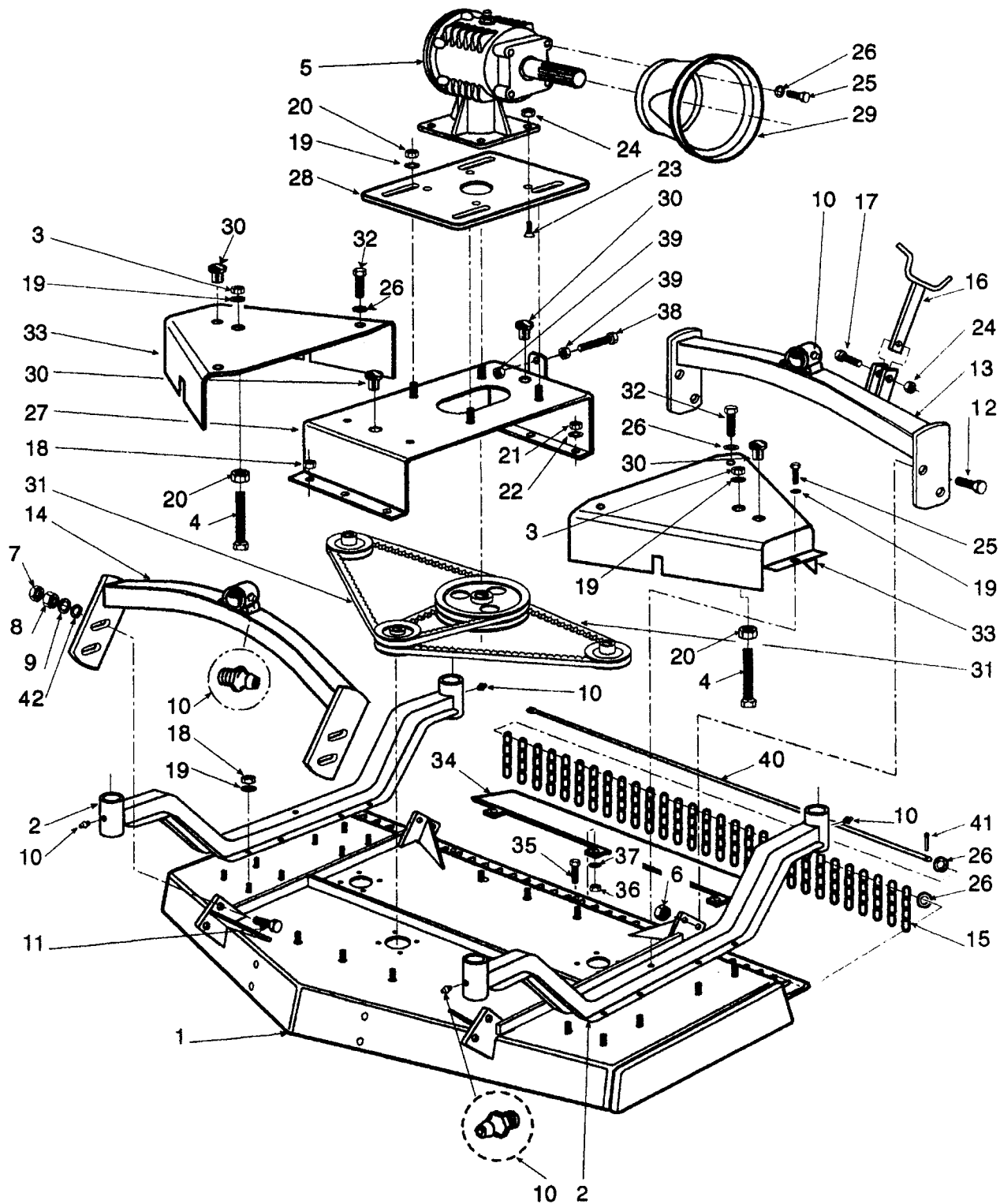

Rotomec: Cyclone 'Flex'

N.	COD.	DESCRIZIONE	DESCRIPTION	DESCRIPTION	BESCHREIBUNG	N.
31	0006798	Cinghia tipo 5VX 630 v.312	Belt type 5VX 630 v.312	Courroie 5VX 630 v.312	Keilriemen 5VX 630 v.312	2
	0006693	Cinghia tipo 5VX 710 v.315	Belt type 5VX 710 v.315	Courroie 5VX 710 v.315	Keilriemen 5VX 710 v.315	2
	0006848	Cinghia tipo 5VX 850 v.317	Belt type 5VX 850 v.317	Courroie 5VX 850 v.317	Keilriemen 5VX 850 v.317	2
32	0033176	Vite TE 10x25	Bolt TE 10x25	Vis TE 10x25	Schraube TE 10x25	4
33	0106987	Protezione cinghia v.312	Belt shield v.312	Protection courroie v.312	Riemenschutz v.312	2
	0108817	Protezione cinghia v.312 da 09/00	Belt shield v.312 - 09/00	Protection courroie v.312 - 09/00	Riemenschutz v.312 - 09/00	
	0206987	Protezione cinghia v.315	Belt shield v.315	Protection courroie v.315	Riemenschutz v.315	2
	0208817	Protezione cinghia v.315 da 09/00	Belt shield v.315 - 09/00	Protection courroie v.315 - 09/00	Riemenschutz v.315 - 09/00	
	0306975	Protezione cinghia v.317	Belt shield v.317	Protection courroie v.317	Riemenschutz v.317	2
	0308817	Protezione cinghia v.317 da 09/00	Belt shield v.317 - 09/00	Protection courroie v.317 - 09/00	Riemenschutz v.317 - 09/00	
34	0108420	Prolunga posteriore v.312	Rear extension v.312	Prolonge arrière v.312	Hintere Verlängerung v.312	1
	0208420	Prolunga posteriore v.315	Rear extension v.315	Prolonge arrière v.315	Hintere Verlängerung v.315	1
	0308420	Prolunga posteriore v.317	Rear extension v.317	Prolonge arrière v.317	Hintere Verlängerung v.317	1
35	0015012	Vite TE 8x20	Bolt TE 8x20	Vis TE 8x20	Schraube TE 8x20	3
36	0001806	Dado D.8	Nut D.8	Ecrou D.8	Mutter D.8	3
37	0003144	Rosetta elastica D.8	Spring washer D.8	Rondelle élastique D.8	Sprengring D.8	3
38	0006547	Vite TE 12x90	Bolt TE 12x90	Vis TE 12x90	Schraube TE 12x90	1
39	0001106	Dado D.12	Nut D.12	Ecrou D.12	Mutter D.12	2
40	0106762	Asta catene v.312	Chain rod v.312	Rond porte-chaîne v.312	Kettenhaltestange v.312	1
	0206762	Asta catene v.315	Chain rod v.315	Rond porte-chaîne v.315	Kettenhaltestange v.315	1
	0306762	Asta catene v.317	Chain rod v.317	Rond porte-chaîne v.317	Kettenhaltestange v.317	1
41	0044156	Copiglia D.4x25	Cotter pin D.4x25	Goupille D.4x25	Splint D.4x25	2
42	0008568	Rondella piana D.16	Flat washer D.16	Rondelle plate D.16	Flache Scheibe D.16	4

Rotomec: Cyclone 'Flex'

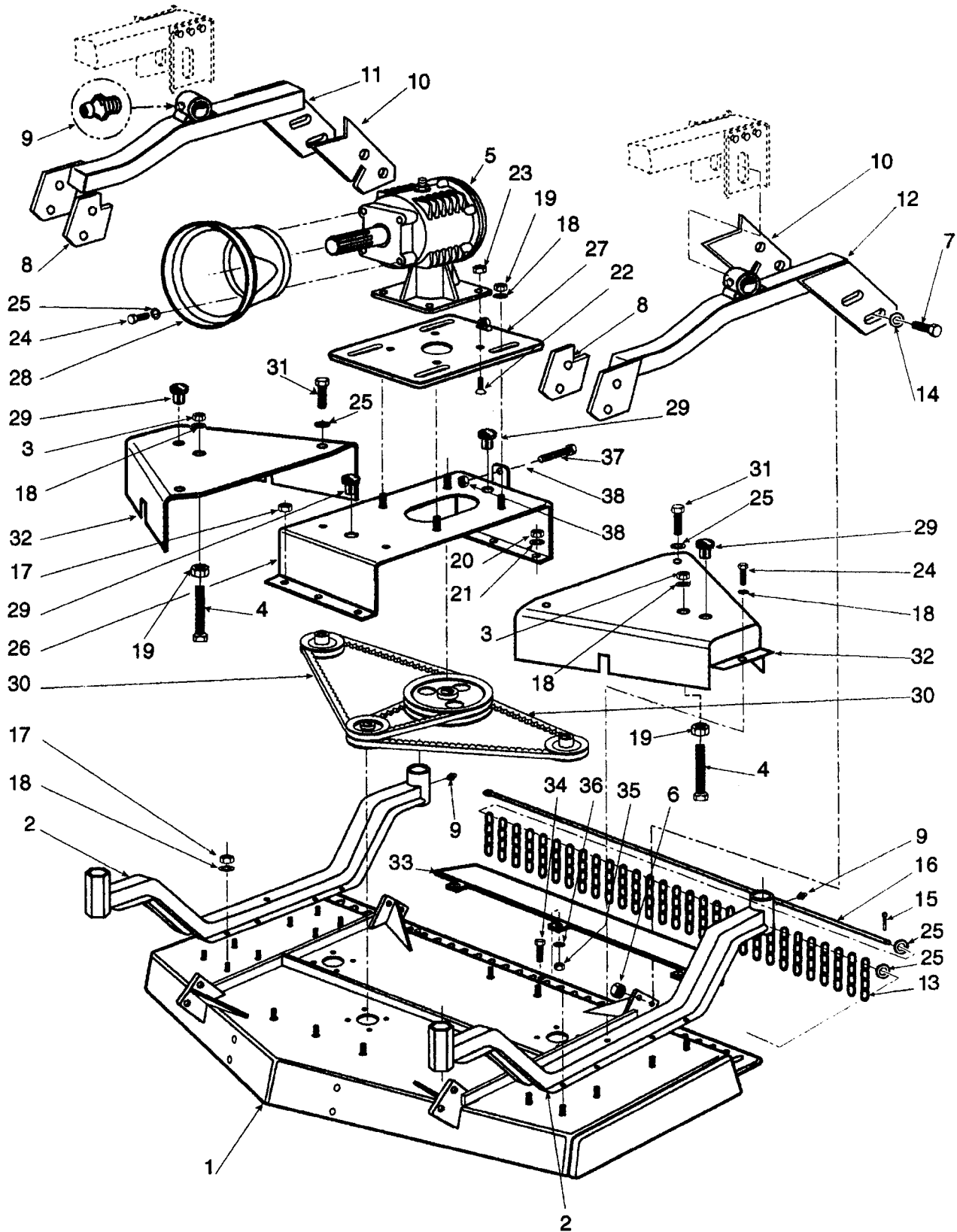

Rotomec: Cyclone 'Flex'

N.	COD.	DESCRIZIONE	DESCRIPTION	DESCRIPTION	BESCHREIBUNG	N.
1	0206903	Telaio v. 312	Frame v. 312	Châssis v. 312	Rahmen v. 312	1
	0306900	Telaio v. 315-317	Frame v. 315-317	Châssis v. 315-317	Rahmen v. 315-317	1
2	0058530	Braccio ruotina v. 312	Wheel arm v. 312	Bras de roue v. 312	Radarm v. 312	2
	0258526	Braccio ruotina v. 312 da 09/00	Wheel arm v. 312 - 09/00	Bras de roue v. 312 - 09/00	Radarm v. 312 - 09/00	
	0058540	Braccio ruotina v. 315-317	Wheel arm v. 315-317	Bras de roue v. 315-317	Radarm v. 315-317	2
	0358526	Braccio ruotina v. 315-317 da 09/00	Wheel arm v. 315-317 - 09/00	Bras de roue v. 315-317 - 09/00	Radarm v. 315-317 - 09/00	
3	0015237	Dado D.10	Nut D.10	Ecrou D.10	Mutter D.10	2
4	0006943	Vite TE 10x120 da 09/00	Bolt TE 10x120 - 09/00	Vis TE 10x120 - 09/00	Schraube TE 10x120 - 09/00	2
5	0500641	Gruppo completo	Complete gearbox	Boîtier complet	Komplette Gehäusegruppe	1
	0500642	Gruppo completo-01/01	Complete gearbox-01/01	Boîtier complet-01/01	Komplette Gehäusegruppe-01/01	1
6	0005581	Dado D.16	Nut D.16	Ecrou D.16	Mutter D.16	8
7	0006577	Vite TE 16x60	Bolt TE 16x60	Vis TE 16x60	Schraube TE 16x60	8
8	0058418	Piastra corta v. 312-315-317	Short plate v. 312-315-317	Plaque courte v. 312-315-317	Kurze Platte v. 312-315-317	2
9	0001065	Ingrassatore	Grease fitting	Graisseur	Schmiernippel	4
10	0058419	Piastra lunga v. 312-315-317	Long plate v. 312-315-317	Plaque longue v. 312-315-317	Lange Platte v. 312-315-317	2
11	0158400	Attacco dx v. 312	Right hitch v.312	Attelage droit v.312	Rechter Anschluß v.312	1
	0158430	Attacco dx v. 315-317	Right hitch v. 315-317	Attelage droit v. 315-317	Rechter Anschluß v. 315-317	1
12	0258400	Attacco sx v. 312	Left hitch v.312	Attelage gauche v.312	Linker Anschluß v.312	1
	0258430	Attacco sx v. 315-317	Left hitch v. 315-317	Attelage gauche v. 315-317	Linker Anschluß v. 315-317	
13	0006764	Catena	Chain	Chaîne	Kette	
14	0008568	Rondella piana D. 16	Flat washer D. 16	Rondelle plate D. 16	Flache Scheibe D. 16	4
15	0044156	Copiglia D.4x25	Cotter pin D.4x25	Goupille D.4x25	Splint D.4x25	2
16	0206762	Asta catene v. 312	Chain rod v. 312	Rond porte-chaîne v. 312	Kettenhaltestange v. 312	1
	0306762	Asta catene v. 315-317	Chain rod v. 315-317	Rond porte-chaîne v. 315-317	Kettenhaltestange v. 315-317	1
17	0030156	Dado D.10	Nut D.10	Ecrou D.10	Mutter D.10	19
18	0030157	Rondella piana D. 10	Flat washer D. 10	Rondelle plate D. 10	Flache Scheibe D. 10	22
19	0014106	Dado autobloccante D.10	Locking nut D.10	Ecrou D.10	Mutter D.10	6
20	0001279	Dado D.10	Nut D.10	Ecrou D.10	Mutter D.10	3
21	0001280	Rosetta elastica D.10	Spring washer D.10	Rondelle élastique D.10	Sprengring D.10	3
22	0074183	Vite TSPEI 12x40	Bolt TSPEI 12x40	Vis TSPEI 12x40	Schraube TSPEI 12x40	4
23	0030064	Dado D.12	Nut D.12	Ecrou D.12	Mutter D.12	4
24	0006349	Vite TE 10x20	Bolt TE 10x20	Vis TE 10x20	Schraube TE 10x20	4
25	0002034	Rondella piana D. 10	Flat washer D. 10	Rondelle élastique D.10	Flache Scheibe D. 10	14
26	0006875	Piastra centrale v.312	Central plate v.312	Plaque centrale v.312	Zentrale Platte v.312	1
	0006913	Piastra centrale v.315-317	Central plate v.315-317	Plaque centrale v.315-317	Zentrale Platte v.315-317	1
27	0006541	Piastra supporto scatola	Gearbox support plate	Plaque support boîtier	Gehäusestützplatte	1
28	0008663	Protezione cardano	Shaft protection	Protection arbre	Kardangelenschutz	1
29	0006647	Tappo	Cap	Bouchon d'huile	Deckel	4
30	0006693	Cinghia tipo 5VX 710 v.312	Belt type 5VX 710 v.312	Courroie 5VX 710 v.312	Keiriemen 5VX 710 v.312	2
	0006848	Cinghia tipo 5VX 850 v.315-317	Belt type 5VX 850 v.315-317	Courroie 5VX 850 v.315-317	Keiriemen 5VX 850 v.315-317	2

Rotomec: Cyclone 'Flex'

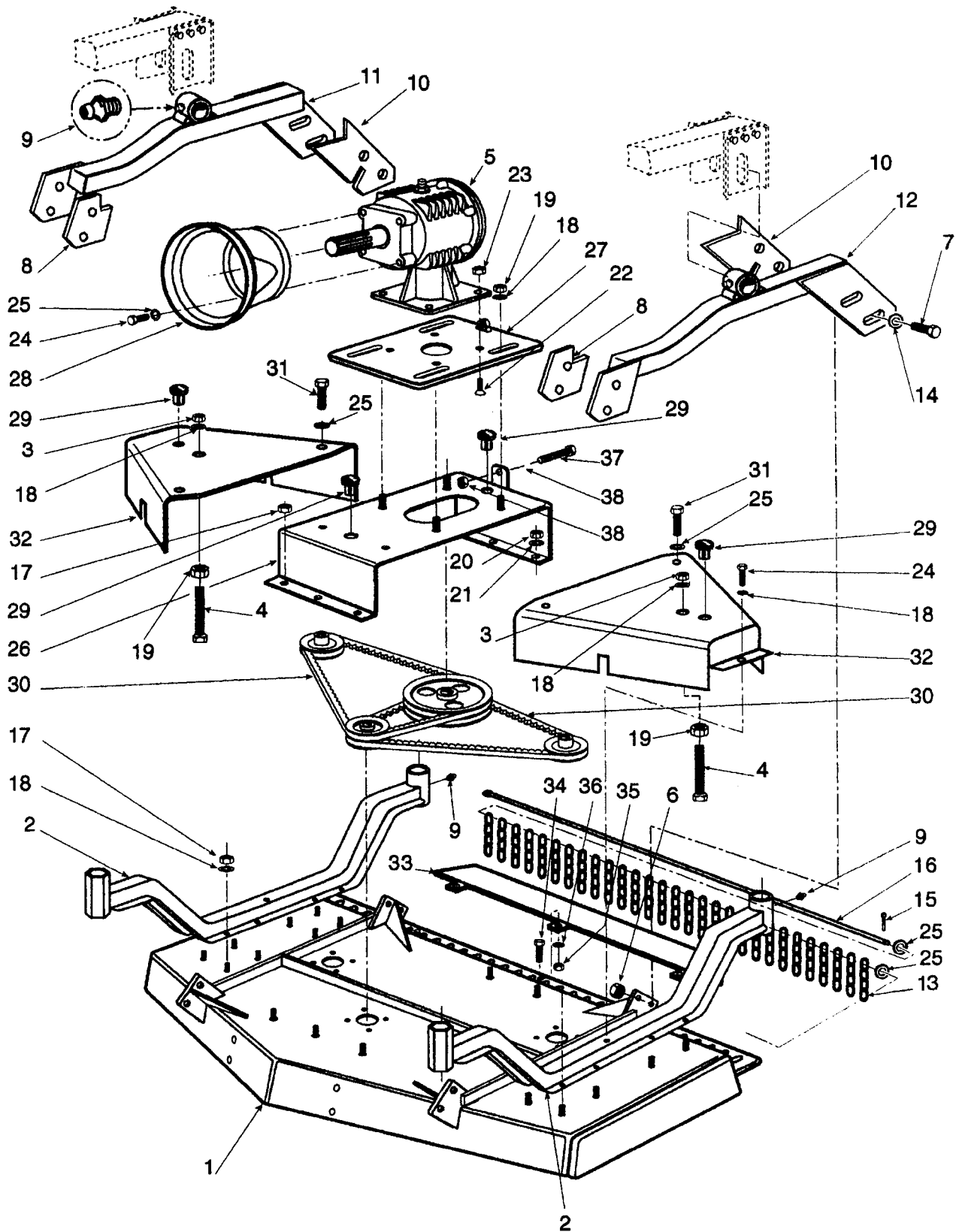

Rotomec: Cyclone 'Flex'

N.	COD.	DESCRIZIONE	DESCRIPTION	DESCRIPTION	BESCHREIBUNG	N.
31	0033176	Vite TE 10x25	Bolt TE 10x25	Vis TE 10x25	Schraube TE 10x25	4
32	0206987	Protezione cinghie v.312	Belt shield v.312	Protection courroie v.312	Riemenschutz v.312	2
	0206989	Protezione cinghie v.312 da 09/00	Belt shield v.312 - 09/00	Protection courroie v.312 - 09/00	Riemenschutz v.312 - 09/00	
	0306975	Protezione cinghie v.315-317	Belt shield v.315-317	Protection courroie v.315-317	Riemenschutz v.315-317	2
	0306989	Protezione cinghie v.315-317 da 09/00	Belt shield v.315-317 - 09/00	Protection courroie v.315-317 - 09/00	Riemenschutz v.315-317 - 09/00	
33	0208420	Prolunga posteriore v.312	Rear extension v.312	Prolonge arrière v.312	Hintere Verlängerung v.312	1
	0308420	Prolunga posteriore v.315-317	Rear extension v.315-317	Prolonge arrière v.315-317	Hintere Verlängerung v.315-317	1
34	0015012	Vite TE 8x20	Bolt TE 8x20	Vis TE 8x20	Schraube TE 8x20	3
35	0001806	Dado D.8	Nut D.8	Ecrou D.8	Mutter D.8	3
36	0003144	Rosetta elastica D.8	Spring washer D.8	Rondelle plate D.8	Sprengring D.8	3
37	0006547	Vite TE 12x90	Bolt TE 12x90	Vis TE 12x90	Schraube TE 12x90	1
38	0001106	Dado D.12	Nut D.12	Ecrou D.12	Mutter D.12	2

Rotomec: Cyclone 'Flex'

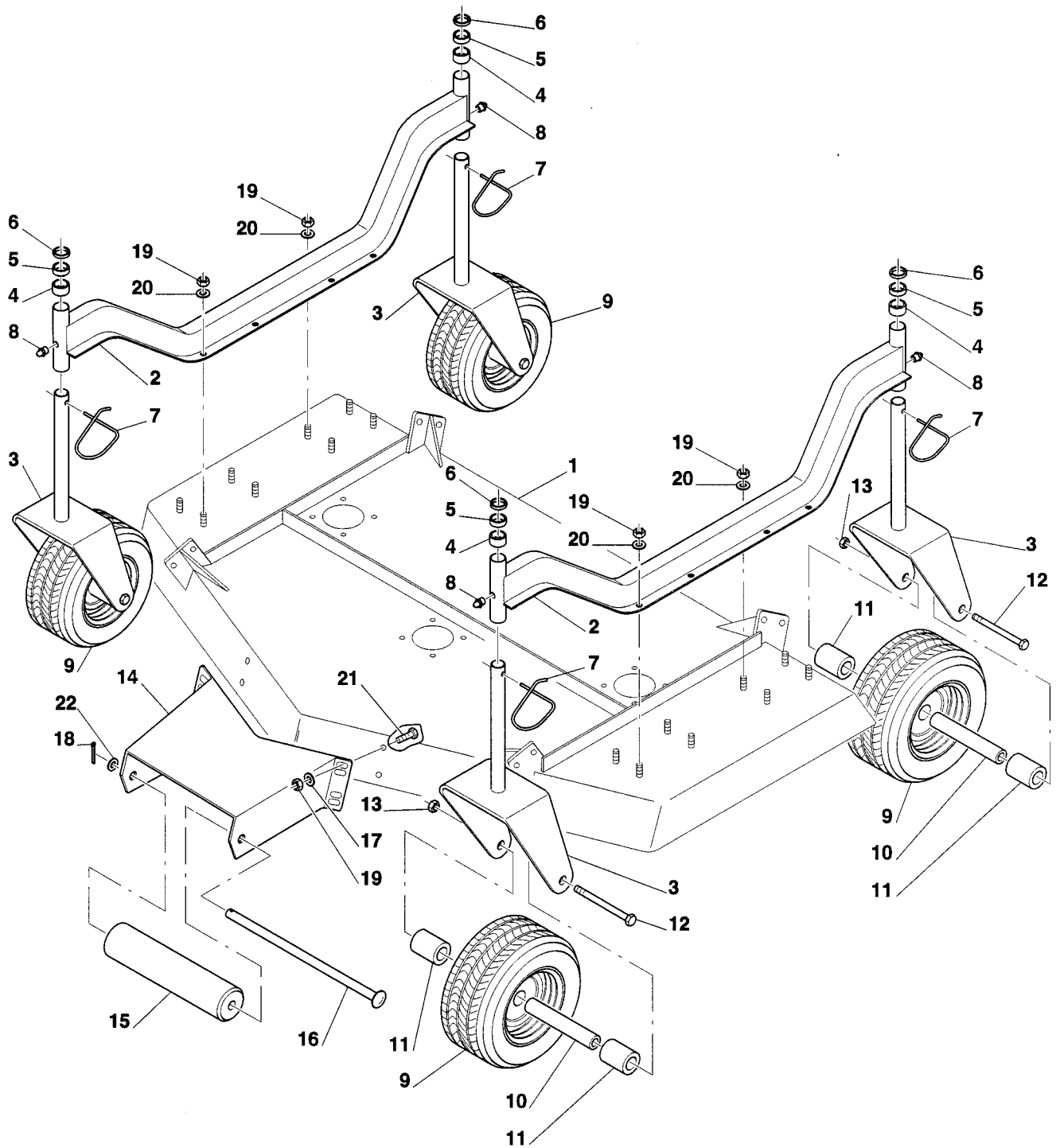

Rotomec: Cyclone 'Flex'

N.	COD.	DESCRIZIONE	DESCRIPTION	DESCRIPTION	BESCHREIBUNG	N.
1	0106903	Telaio v. 312	Frame v. 312	Châssis v. 312	Rahmen v. 312	2
	0206903	Telaio v. 315	Frame v. 315	Châssis v. 315	Rahmen v. 315	2
	0306900	Telaio v. 317	Frame v.317	Châssis v.317	Rahmen v. 317	2
2	0106939	Braccio ruotina v. 312	Wheel arm v. 312	Bras de roue v. 312	Radarm v. 312	4
	0106941	Braccio ruotina v. 312 da 09/00	Wheel arm v. 312 - 09/00	Bras de roue v. 312 - 09/00	Radarm v. 312 - 09/00	4
	0206939	Braccio ruotina v. 315	Wheel arm v. 315	Bras de roue v. 315	Radarm v. 315	4
	0206941	Braccio ruotina v. 315 da 09/00	Wheel arm v. 315 - 09/00	Bras de roue v. 315 - 09/00	Radarm v. 315 - 09/00	4
	0306932	Braccio ruotina v. 317	Wheel arm v.317	Bras de roue v.317	Radarm v.317	4
	0306941	Braccio ruotina v. 317 da 09/00	Wheel arm v. 317 - 09/00	Bras de roue v. 317 - 09/00	Radarm v.317 - 09/00	4
3	0006946	Forcella porta ruota	Wheel yoke	Fourche pour roue	Gabel für Rad	8
4	0006586	Distanziale 1"	Spacer 1"	Entretoise 1"	Distanzstück 1"	24
5	0006587	Distanziale 1/2"	Spacer 1/2"	Entretoise 1/2"	Distanzstück 1/2"	8
6	0006589	Distanziale 1/4"	Spacer 1/4"	Entretoise 1/4"	Distanzstück 1/4"	16
7	0008783	Molla forcella ruota	Wheel yoke spring	Ressort fourche pour roue	Radgabelfeder	4
8	0001065	Ingrassatore	Grease fitting	Graisseur	Schmiernippel	8
9	0006923Y	Ruota gommata piena	Hard tire	Roue caoutchoutée	Gummirad	8
	0006967	Ruota pneumatica	Air tire	Roue pneumatique	Luftreifen	8
10	0006584	Distanziale interno	Inner spacer	Entretoise interne	Innendistanzstück	8
11	0006585	Distanziale esterno	Outer spacer	Entretoise externe	Außendistanzstück	16
12	0006619	Vite TE 14x150	Bolt TE 14x150	Vis TE 14x150	Schraube TE 14x150	8
13	0030358	Dado D.14	Nut D.14	Ecrou D.14	Mutter D.14	8
14	0009622	Supporto rullo	Roller support	Palier rouleau	Walzenstütze	2
15	0067358	Rullo anteriore	Front roller	Rouleau antérieur	Vordere Walze	2
16	0067363	Perno rullo	Roller pin	Tourillon rouleau	Rollerzapfen	2
17	0002034	Rondella piana D.10	Flat washer D.10	Rondelle plate D.10	Flache Scheibe D.10	8
18	0044156	Copiglia D.4x25	Cotter pin D.4x25	Goupille D.4x25	Splint D.4x25	2
19	0030156	Dado D.10	Nut D.10	Ecrou D.10	Mutter D.10	40
20	0030157	Rondella piana D.10	Flat washer D.10	Rondelle plate D.10	Flache Scheibe D.10	32
21	0006349	Vite TE 10x20	Bolt TE 10x20	Vis TE 10x20	Schraube TE 10x20	8
22	0008568	Rondella piana D.16	Flat washer D.16	Rondelle plate D.16	Flache Scheibe D.16	4

Rotomec: Cyclone 'Flex'

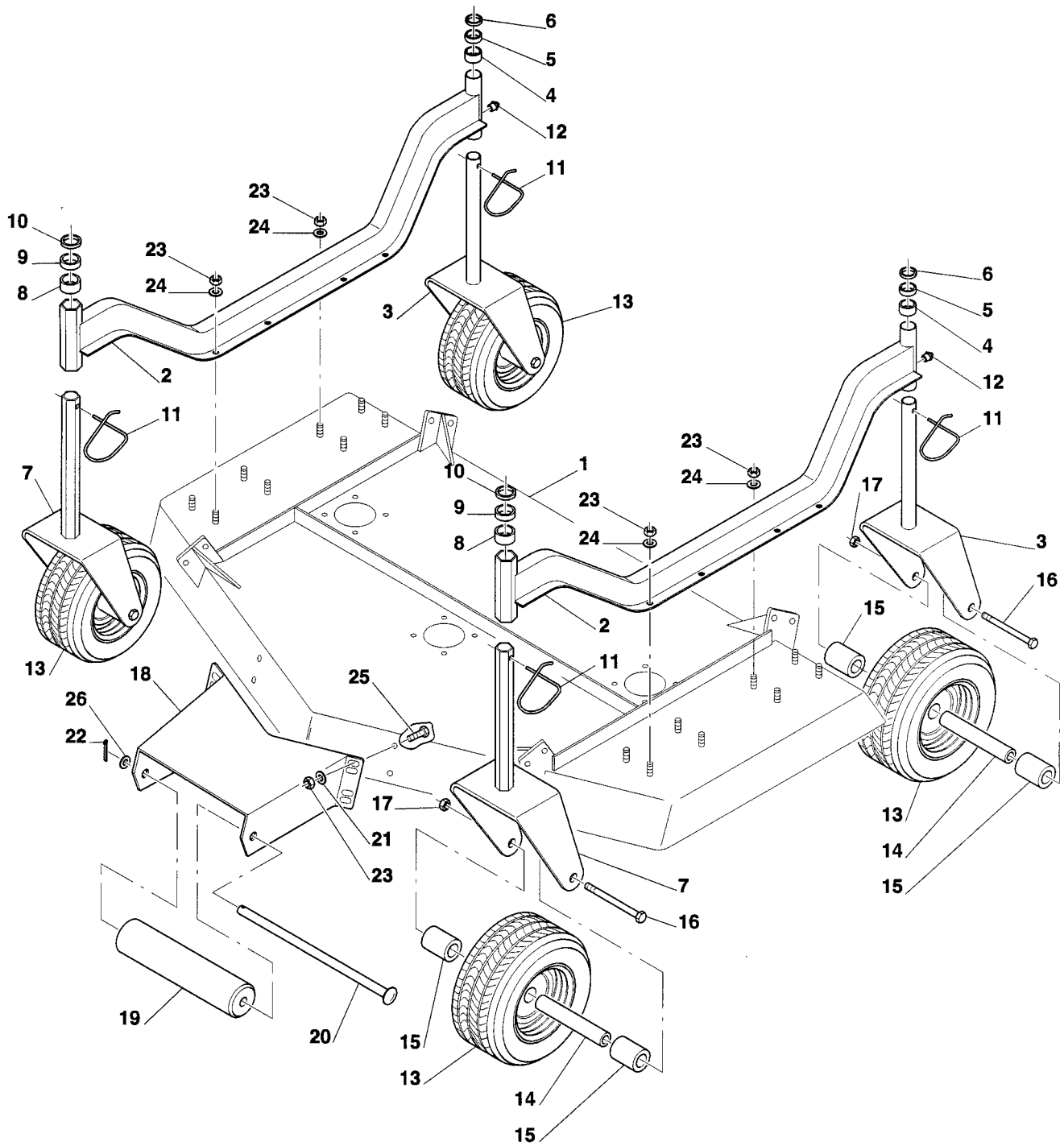

Rotomec: Cyclone 'Flex'

N.	COD.	DESCRIZIONE	DESCRIPTION	DESCRIPTION	BESCHREIBUNG	N.
1	0206903	Telaio v. 312	Frame v. 312	Châssis v. 312	Rahmen v. 312	1
	0306900	Telaio v. 315-317	Frame v. 315-317	Châssis v. 315-317	Rahmen v. 315-317	1
2	0058530	Braccio ruotina v. 312	Wheel arm v. 312	Bras de roue v. 312	Radarm v. 312	2
	0258526	Braccio ruotina v. 312 da 09/00	Wheel arm v. 312 - 09/00	Bras de roue v. 312 - 09/00	Radarm v. 312 - 09/00	2
	0058540	Braccio ruotina v. 315-317	Wheel arm v. 315-317	Bras de roue v. 315-317	Radarm v. 315-317	2
	0358526	Braccio ruotina v. 315-317 da 09/00	Wheel arm v. 315-317 - 09/00	Bras de roue v. 315-317 - 09/00	Radarm v. 315-317 - 09/00	2
3	0006946	Forcella porta ruota	Wheel yoke	Fourche pour roue	Gabel für Rad	2
4	0006586	Distanziale 1"	Spacer 1"	Entretoise 1"	Distanzstück 1"	6
5	0006587	Distanziale 1/2"	Spacer 1/2"	Entretoise 1/2"	Distanzstück 1/2"	2
6	0006589	Distanziale 1/4"	Spacer 1/4"	Entretoise 1/4"	Distanzstück 1/4"	4
7	0058551	Forcella porta ruota	Wheel yoke	Fourche pour roue	Gabel für Rad	2
8	0058555	Distanziale 1"	Spacer 1"	Entretoise 1"	Distanzstück 1"	6
9	0058556	Distanziale 1/2"	Spacer 1/2"	Entretoise 1/2"	Distanzstück 1/2"	2
10	0058557	Distanziale 1/4"	Spacer 1/4"	Entretoise 1/4"	Distanzstück 1/4"	4
11	0008783	Molla forcella ruota	Wheel yoke spring	Ressort fourche pour roue	Radgabelfeder	4
12	0001065	Ingrassatore	Grease fitting	Graisseur	Schmiernippel	2
13	0006923Y	Ruota gommata piena	Hard tire	Roue caoutchoutée	Gummirad	4
	0006967	Ruota pneumatica	Air tire	Roue pneumatique	Luftreifen	4
14	0006584	Distanziale interno	Inner spacer	Entretoise interne	Innendistanzstück	4
15	0006585	Distanziale esterno	Outer spacer	Entretoise externe	Außendistanzstück	8
16	0006619	Vite TE 14x150	Bolt TE 14x150	Vis TE 14x150	Schraube TE 14x150	4
17	0030358	Dado D.14	Nut D.14	Ecrou D.14	Mutter D.14	4
18	0009622	Supporto rullo	Roller support	Palier rouleau	Walzenstütze	1
19	0067358	Rullo anteriore	Front roller	Rouleau antérieur	Vordere Walze	1
20	0067363	Perno rullo	Roller pin	Tourillon rouleau	Rollerzapfen	1
21	0002034	Rondella piana D.10	Flat washer D.10	Rondelle plate D.10	Flache Scheibe D.10	4
22	0044156	Copiglia D.4x25	Cotter pin D.4x25	Goupille D.4x25	Splint D.4x25	1
23	0030156	Dado D.10	Nut D.10	Ecrou D.10	Mutter D.10	20
24	0030157	Rondella piana D.10	Flat washer D.10	Rondelle plate D.10	Flache Scheibe D.10	16
25	0006349	Vite TE 10x20	Bolt TE 10x20	Vis TE 10x20	Schraube TE 10x20	4
26	0008568	Rondella piana D.16	Flat washer D.16	Rondelle plate D.16	Flache Scheibe D.16	4

Rotomec: Cyclone 'Flex'

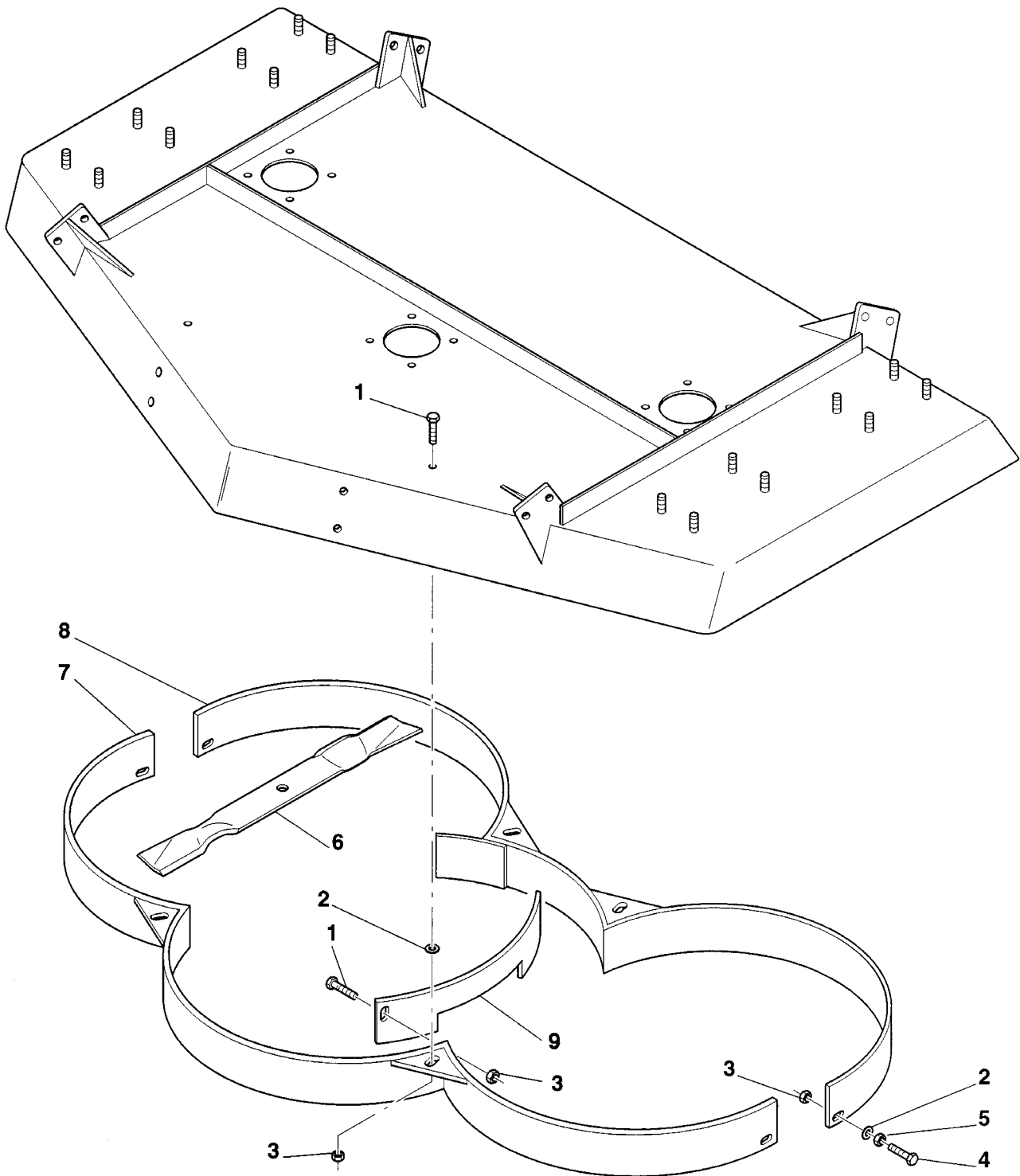

Rotomec: Cyclone 'Flex'

N.	COD.	DESCRIZIONE	DESCRIPTION	DESCRIPTION	BESCHREIBUNG	N.
1	0006349	Vite TE 10x20	Bolt TE 10x20	Vis TE 10x20	Schraube TE 10x20	8
2	0002034	Rondella piana D.10	Flat washer D.10	Rondelle plate D.10	Flache Scheibe D.10	6
3	0030156	Dado D.10	Nut D.10	Ecrou D.10	Mutter D.10	10
4	0091281	Vite TE 10x35	Bolt TE 10x35	Vis TE 10x35	Schraube TE 10x35	2
5	0003038	Dado D.12	Nut D.12	Ecrou D.12	Mutter D.12	2
6	0006795M	Coltello sminuzzatore v.120	Mulching blade v.120	Couteau hacheur v.120	Hackmesser v.120	3
	0006641M	Coltello sminuzzatore v.150	Mulching blade v.150	Couteau hacheur v.150	Hackmesser v.150	3
	0006845M	Coltello sminuzzatore v.180	Mulching blade v.180	Couteau hacheur v.180	Hackmesser v.180	3
7	0006782	Convogliatore v.120	Baffling v.120	Convoyeur v.120	Förderer v.120	1
	0006777	Convogliatore v.150	Baffling v.150	Convoyeur v.150	Förderer v.150	1
	0006784	Convogliatore v.180	Baffling v.180	Convoyeur v.180	Förderer v.180	1
8	0006776	Convogliatore v.120	Baffling v.120	Convoyeur v.120	Förderer v.120	1
	0006783	Convogliatore v.150	Baffling v.150	Convoyeur v.150	Förderer v.150	1
	0006778	Convogliatore v.180	Baffling v.180	Convoyeur v.180	Förderer v.180	1
9	0006780	Lamiera di supporto	Guard support	Soutien protection	Anschlußblech	2

Rotomec: Cyclone 'Flex'

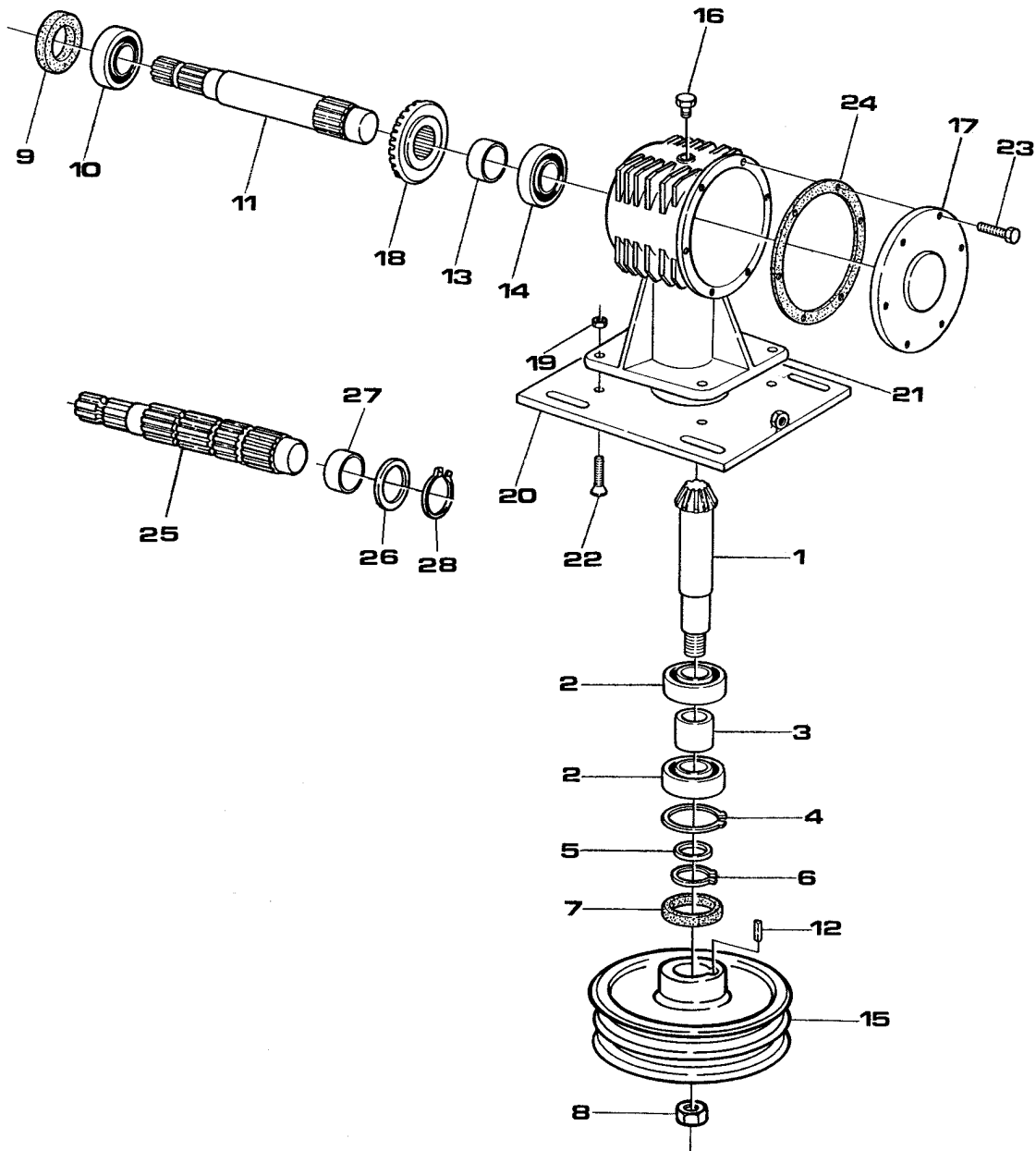

Rotomec: Cyclone 'Flex'

N.	COD.	DESCRIZIONE	DESCRIPTION	DESCRIPTION	BESCHREIBUNG	N.
1	0006676	Pignone conico	Pinion gear	Pignon conique	Kegelrad	1
	0058478	Pignone conico-09/00	Pinion Gear-09/00	Pignon conique-09/00	Kegelrad-09/00	1
	0058479	Pignone conico-01/01	Pinion Gear-01/01	Pignon conique-01/01	Kegelrad-01/01	1
2	0012149	Cuscinetto 6208	Bearing 6208	Roulement 6208	Lager 6208	2
3	0006687	Distanziale pignone	Spacer	Entretoise pignon	Ritzeldistanzstück	1
4	0001154	Seeger interno D.80	Inner snap ring D.80	Circlip interne D.80	Innenseegerring D.80	1
5	0006685	Anello di spessoramento	Spacer washer	Anneau d'épaisseur	Distanzring	1
6	0008138	Seeger esterno D.40	Outer snap ring D.40	Circlip externe D.40	Außenseegerring D.40	1
7	0006684	Paraolio 40.80.10	Oil seal 40.80.10	Pare-huile 40.80.10	Simmering 40.80.10	1
8	0006698	Dado D.25	Nut D.25	Ecrou D.25	Mutter D.25	1
9	0002295	Paraolio 35.62.10	Oil seal 35.62.10	Pare-huile 35.62.10	Simmering 35.62.10	1
10	0025332	Cuscinetto 6207	Bearing 6207	Roulement 6207	Lager 6207	1
11	0006657	Albero P.D.F.	Input shaft	Arbre P.D.F.	Zapfwelle	1
	0058465	Albero P.D.F.-09/00	Input shaft-09/00	Arbre P.D.F.-09/00	Zapfwelle-09/00	1
	0058464	Albero P.D.F.-01/01	Input shaft-01/01	Arbre P.D.F.-01/01	Zapfwelle-01/01	1
12	0006689	Linguetta 7x8x30	Key 7x8x30	Clavette 7x8x30	Schlüssel 7x8x30	1
13	0006661	Distanziale posteriore	Rear spacer	Entretoise postérieure	Hinteres Distanzstück	1
14	0044217	Cuscinetto 30305	Bearing 30305	Roulement 30305	Lager 30305	1
	0058472	Cuscinetto 30206-09/00	Bearing 30206-09/00	Roulement 30206-09/00	Lager 30206-09/00	1
15	0006692	Puleggia SPB 250x2	Pulley SPB 250x2	Poulie SPB 250x2	Scheibe SPB 250x2	1
16	0001107	Sfiatatoio	Breather cap	Bouchon d'huile	Gehäuseentlüfter	1
17	0006656	Coperchiella corona	Gear cover	Couvercle couronne	Kranzhaube	1
18	0006677	Corona conica	Ring gear	Couronne conique	Tellerrad	1
	0058470	Corona conica-09/00	Ring gear-09/00	Couronne conique-09/00	Tellerrad-09/00	1
	0058477	Corona conica-01/01	Ring gear-01/01	Couronne conique-01/01	Tellerrad-01/01	1
19	0030064	Dado D.12	Nut D.12	Ecrou D.12	Mutter D.12	4
20	0006541	Piastra supporto scatola	Gearbox support plate	Plaque support boîtier	Gehäusestützplatte	1
21	0006658	Scatola ingranaggi	Gearbox	Boîtier	Getriebekasten	1
22	0074183	Vite TSPEI 12x40	Bolt TSPEI 12x40	Vis TSPEI 12x40	Schraube TSPEI 12x40	4
23	0006349	Vite TE 10x20	Bolt TE 10x20	Vis TE 10x20	Schraube TE 10x20	6
24	0030193	Guarnizione	Gasket	Joint d'étanchéité	Dichtung	-
	0130193	Guarnizione	Gasket	Joint d'étanchéité	Dichtung	-
25	0005556	Albero P.D.F. antiorario	Input shaft w/ccw rotation	Arbre P.D.F. rot. anti-horaire	Zapfwelle gegen den Uhrzeigersinn	1
26	0144233	Anello di spessoramento	Spacer washer	Anneau d'épaisseur	Distanzring	1
27	0006662	Distanziale	Spacer	Entretoise	Distanzstück	1
28	0042122	Seeger esterno D.35	Outer snap ring D.35	Circlip externe D.35	Außenseegerring D.35	1
	0500638A	Gruppo scatola rot. oraria	Gearbox w/cw rotation	Boîtier rotation horaire	Gehäusegruppe Rotation im Uhrzeigersinn	
	0500639A	Gruppo scatola rot. antioraria	Gearbox w/ccw rotation	Boîtier rotation anti-horaire	Gehäusegruppe Rotation gegen den Uhrzeigersinn	
	0500641	Gruppo scatola rot. oraria 09.2000	Gearbox w/cw rotation 09.2000	Boîtier rotation horaire 09.2000	Gehäusegruppe Rotation im Uhrzeigersinn-09.2000	
	0500642	Gruppo scatola rot. oraria 01.2001	Gearbox w/cw rotation 01.2001	Boîtier rotation horaire 01.2001	Gehäusegruppe Rotation im Uhrzeigersinn-01.2001	
	0500643	Gruppo scatola rot. antioraria 01.2001	Gearbox w/ccw rotation 01.2001	Boîtier rotation anti-horaire 01.2001	Gehäusegruppe Rotation gegen den Uhrzeigersinn 01.2001	

Rotomec: Cyclone 'Flex'

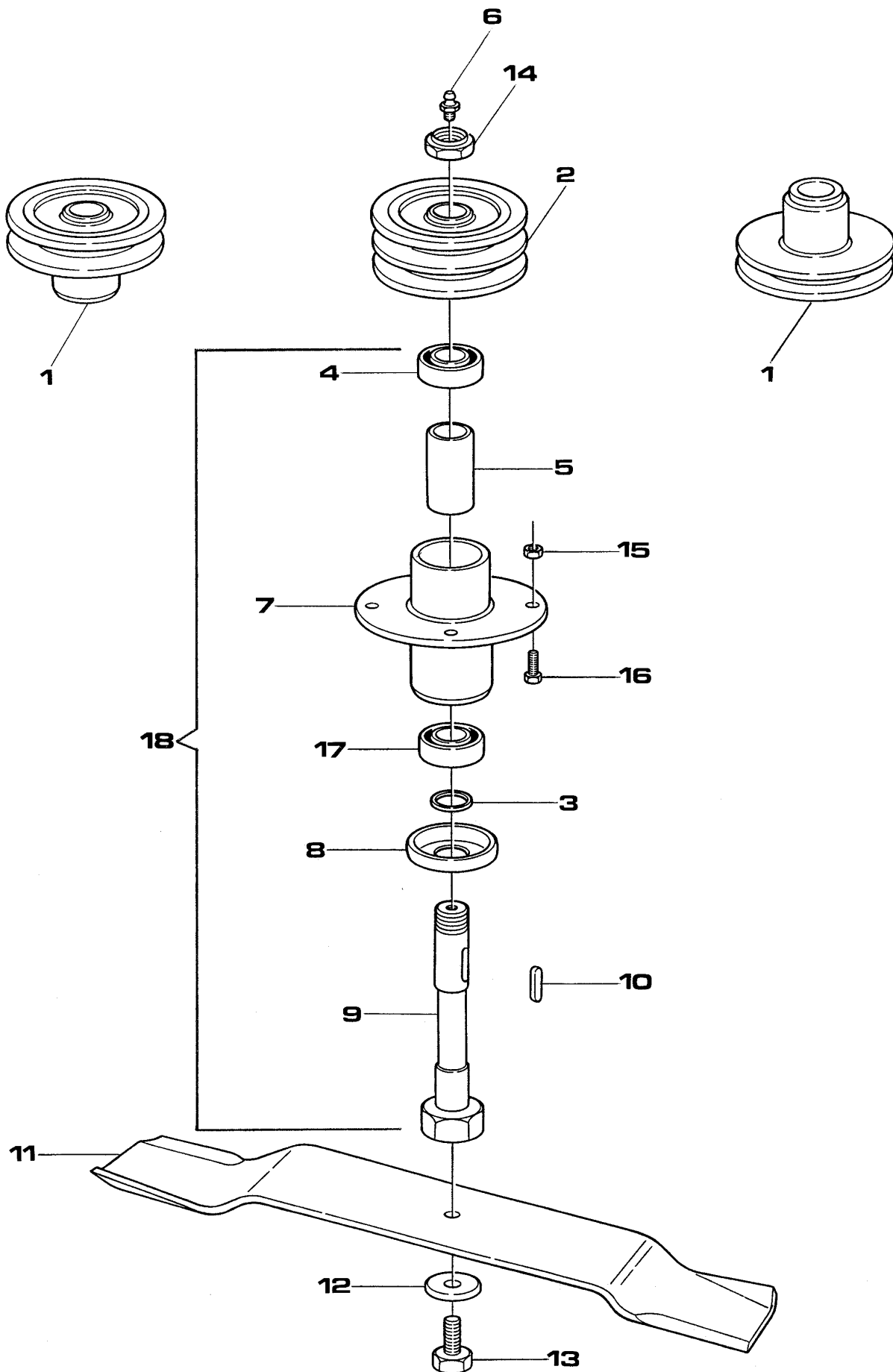

Rotomec: Cyclone 'Flex'

N.	COD.	DESCRIZIONE	DESCRIPTION	DESCRIPTION	BESCHREIBUNG	N.
1	0006792	Puleggia SPB 120x1 v.120	Pulley SPB 120x1 v.120	Poulie SPB 120x1 v.120	Scheibe SPB 120x1 v.120	2
	0006622	Puleggia SPB 130x1 v.150	Pulley SPB 130x1 v.150	Poulie SPB 130x1 v.150	Scheibe SPB 130x1 v.150	2
	0006842	Puleggia SPB 160x1 v.180	Pulley SPB 160x1 v.180	Poulie SPB 160x1 v.180	Scheibe SPB 160x1 v.180	2
	0006862	Puleggia SPB 190x1 v.210	Pulley SPB 190x1 v.210	Poulie SPB 190x1 v.210	Scheibe SPB 190x1 v.210	2
2	0006791	Puleggia SPB 120x2 v.120	Pulley SPB 120x2 v.120	Poulie SPB 120x2 v.120	Scheibe SPB 120x2 v.120	1
	0006621	Puleggia SPB 130x2 v.150	Pulley SPB 130x2 v.150	Poulie SPB 130x2 v.150	Scheibe SPB 130x2 v.150	1
	0006841	Puleggia SPB 160x2 v.180	Pulley SPB 160x2 v.180	Poulie SPB 160x2 v.180	Scheibe SPB 160x2 v.180	1
	0006861	Puleggia SPB 190x2 v.210	Pulley SPB 190x2 v.210	Poulie SPB 190x2 v.210	Scheibe SPB 190x2 v.210	1
3	0006606	Anello di spessoramento	Spacer washer	Anneau d'épaisseur	Distanzring	3
4	0006634A	Cuscinetto 6205-Z	Bearing 6205-Z	Roulement 6205-Z	Lager 6205-Z	3
5	0006640	Distanziale	Spacer	Entretoise	Distanzstück	3
6	0029036	Ingrassatore	Grease fitting	Graisser	Schmiernippel	3
7	0006648	Supporto rotore	Spindle	Palier rotor	Rotorauflage	3
8	0006636	Coperchiella	Cover	Couvercle	Deckel	3
9	0006649	Albero porta coltello	Spindle shaft	Arbre porte couteau	Messerwelle	3
10	0006639	Linguetta 7x8x25	Key 7x8x25	Clavette 7x8x25	Schlüssel 7x8x25	3
11	0006795	Coltello standard v.120	Standard blade v.120	Couteau standard v.120	Standard Messer v.120	3
	0006641	Coltello standard v.150	Standard blade v.150	Couteau standard v.150	Standard Messer v.150	3
	0006845	Coltello standard v.180	Standard blade v.180	Couteau standard v.180	Standard Messer v.180	3
	0006795M	Coltello sminuzzatore v.120	Mulching blade v.120	Couteau hacheur v.120	Hackmesser v.120	3
	0006641M	Coltello sminuzzatore v.150	Mulching blade v.150	Couteau hacheur v.150	Hackmesser v.150	3
	0006845M	Coltello sminuzzatore v.180	Mulching blade v.180	Couteau hacheur v.180	Hackmesser v.180	3
	0006795B	Coltello espulsore v.120	Highlift blade v.120	Couteau éjecteur v.120	Auswurfmesser v.120	3
	0006641B	Coltello espulsore v.150	Highlift blade v.150	Couteau éjecteur v.150	Auswurfmesser v.150	3
	0006845B	Coltello espulsore v.180	Highlift blade v.180	Couteau éjecteur v.180	Auswurfmesser v.180	3
	0006795F	Coltello piatto v.120	Flat blade v.120	Couteau flat v.120	Flachmesser v.120	3
	0006641F	Coltello piatto v.150	Flat blade v.150	Couteau flat v.150	Flachmesser v.150	3
	0006845F	Coltello piatto v.180	Flat blade v.180	Couteau flat v.180	Flachmesser v.180	3
12	0008560	Molla a tazza	Disc spring	Ressort à disque	Tellerfeder	3
13	0008559	Vite fissa coltello	Blade bolt	Vis de fixation couteau	Messerbefestigungsschraube	3
14	0006698	Dado D.25	Nut D.25	Ecrou D.25	Mutter D.25	3
15	0030156	Dado D.10	Nut D.10	Ecrou D.10	Mutter D.10	12
16	0001008	Vite TE 10x30	Bolt TE 10x30	Vis TE 10x30	Schraube TE 10x30	12
17	0006626A	Cuscinetto 6205-ZZ	Bearing 6205-ZZ	Roulement 6205-ZZ	Lager 6205-ZZ	3
18	0006629C	Gruppo rotore	Spindle assembly	Groupe de rotor	Rotorgruppe	

Rotomec: mod. 312 Cyclone lat.

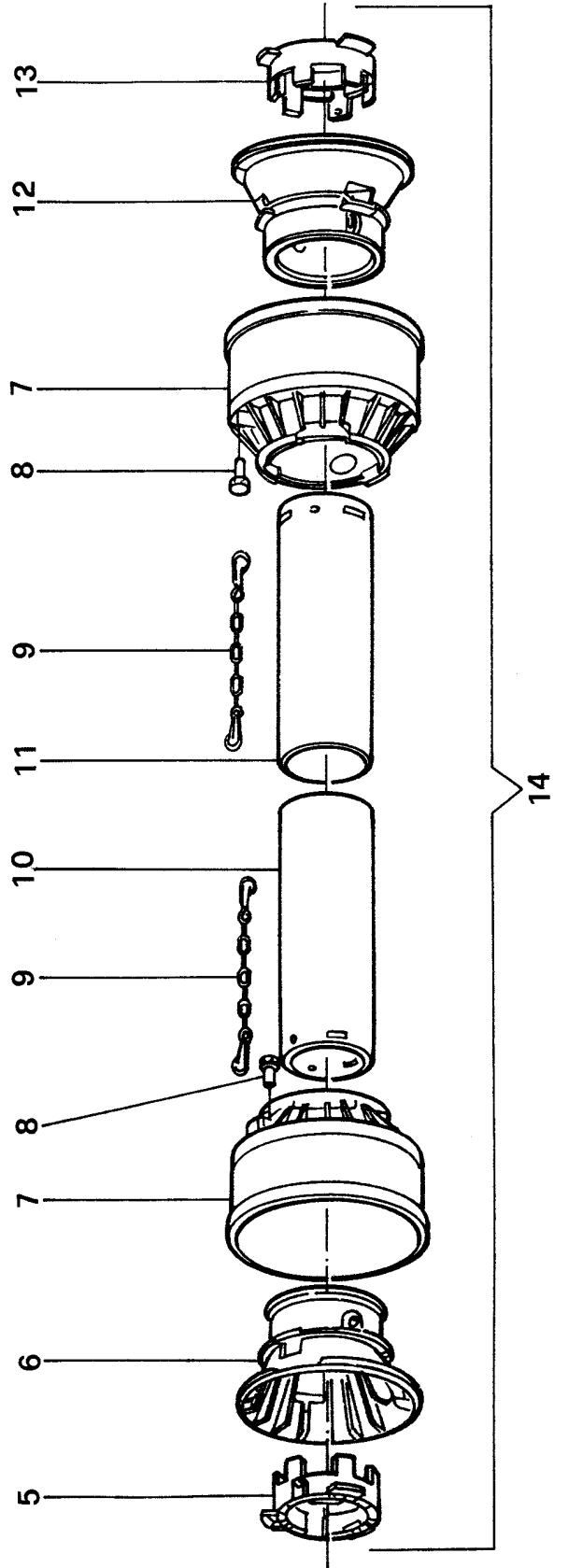
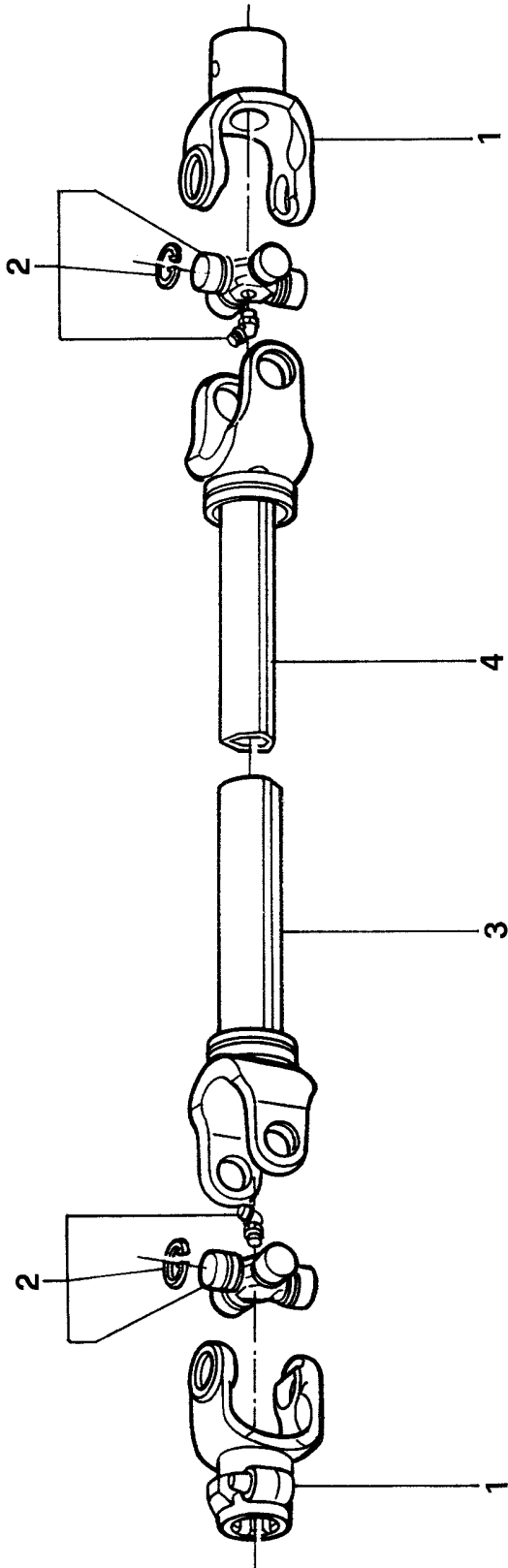

Rotomec: mod. 312 Cyclone lat.

N.	COD.	DESCRIZIONE	DESCRIPTION	DESCRIPTION	BESCHREIBUNG	N.
1	023001E	Forcella P.D.F.	PTO Yoke	Fourche P.D.F.	Aufsteckgabel	2
2	013130E	Crociera	Cross & Bearing	Croisillon	Kreuzgelenk	2
3	1943045C	Tubo esterno	Outer tube	Tube externe	Außenrohr	1
4	1953047C	Tubo interno	Inner tube	Tube interne	Innenrohr	1
5	1784210C	Anello tubo esterno	Outer tube locking ring	Anneau tube externe	Außenrohrring	1
6	1784201C	Controcuffia tubo esterno	Outer tube rigid cone	Contre coiffe tube externe	Außenrohrgegentopf	1
7	1784203C	Cuffia esterna	Outer cone	Coiffe externe	Außenschutztopf	2
8	1784212C	Spina di bloccaggio	Pin	Goupille	Haltestift	2
9	016025E	Catenella	Chain	Chaîne	Kette	2
10	1773043C	Tubo protezione esterna	Female tube shield	Tube protection femelle	Außenschutzrohr	1
11	1872043C	Tubo protezione interna	Male tube shield	Tube protection mâle	Innenschutzrohr	1
12	1784202C	Controcuffia tubo interno	Inner tube rigid cone	Contre coiffe tube interne	Innenrohrgegentopf	1
13	1784211C	Anello tubo interno	Inner tube locking ring	Anneau tube interne	Innenrohrring	1
14	9403443C	Protezione completa	Complete shielding	Protection complète	Kompletter Schutz	1
	0500437	Cardano	PTO shaft	Arbre à cardan	Kardangelenk	

Rotomec: mod. 315 Cyclone lat.

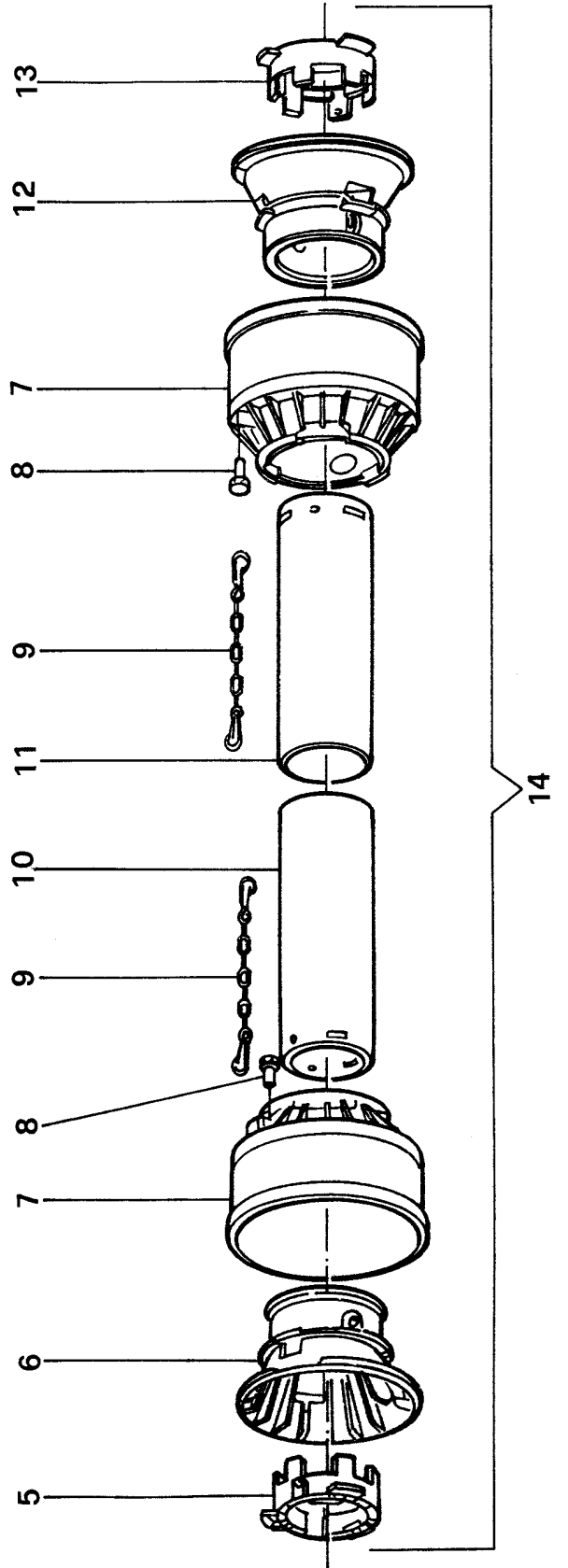
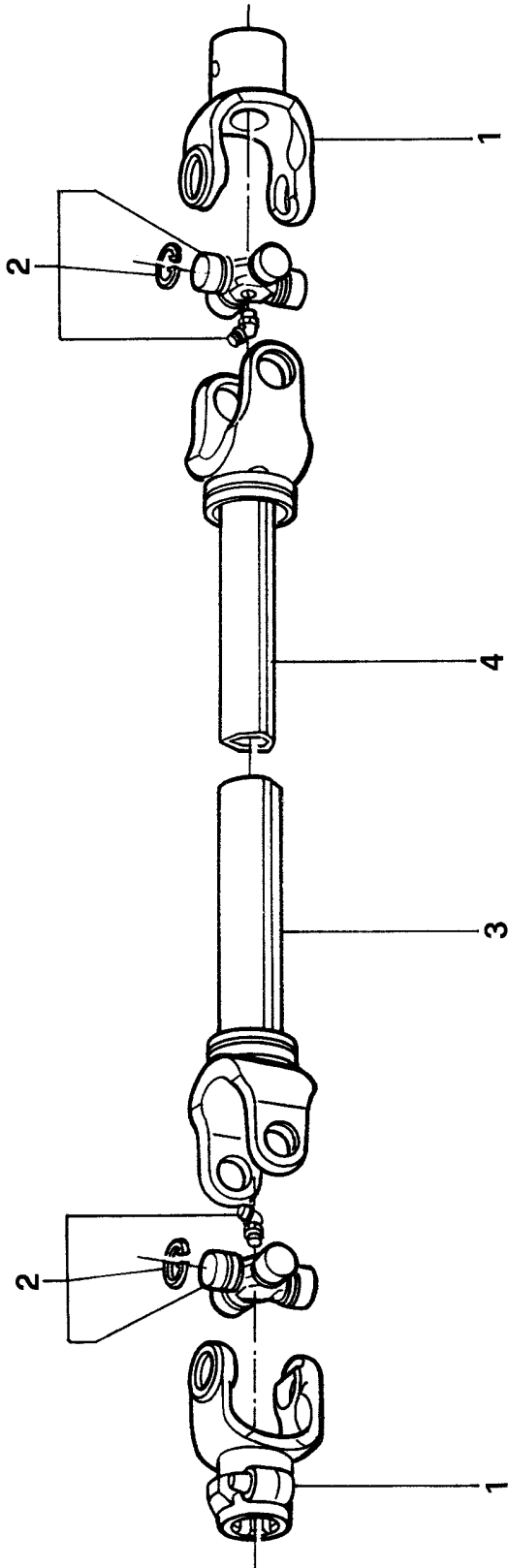

Rotomec: mod. 315 Cyclone lat.

N.	COD.	DESCRIZIONE	DESCRIPTION	DESCRIPTION	BESCHREIBUNG	N.
1	023001E	Forcella P.D.F.	PTO Yoke	Fourche P.D.F.	Aufsteckgabel	2
2	013130E	Crociera	Cross & Bearing	Croisillon	Kreuzgelenk	2
3	1943055C	Tubo esterno	Outer tube	Tube externe	Außenrohr	1
4	1953057C	Tubo interno	Inner tube	Tube interne	Innenrohr	1
5	1784210C	Anello tubo esterno	Outer tube locking ring	Anneau tube externe	Außenrohrring	1
6	1784201C	Controcuffia tubo esterno	Outer tube rigid cone	Contre coiffe tube externe	Außenrohrgegentopf	1
7	1784203C	Cuffia esterna	Outer cone	Coiffe externe	Außenschutztopf	2
8	1784212C	Spina di bloccaggio	Pin	Goupille	Haltestift	2
9	016025E	Catenella	Chain	Chaîne	Kette	2
10	1773053C	Tubo protezione esterna	Female tube shield	Tube protection femelle	Außenschutzrohr	1
11	1872053C	Tubo protezione interna	Male tube shield	Tube protection mâle	Innenschutzrohr	1
12	1784202C	Controcuffia tubo interno	Inner tube rigid cone	Contre coiffe tube interne	Innenrohrgegentopf	1
13	1784211C	Anello tubo interno	Inner locking ring	Anneau tube interne	Innenrohrring	1
14	9403453C	Protezione completa	Complete shielding	Protection complète	Kompletter Schutz	1
	0500438	Cardano	PTO shaft	Arbre à cardan	Kardangelenk	

Rotomec: mod. 317 Cyclone lat.

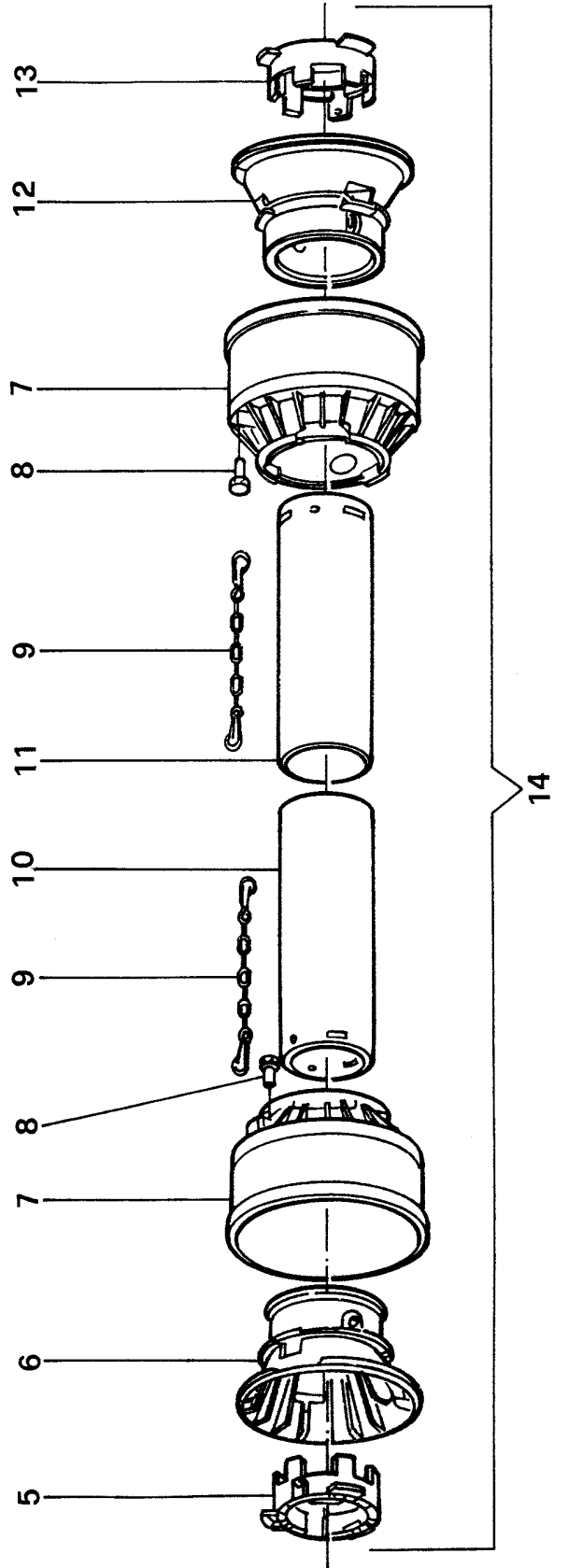
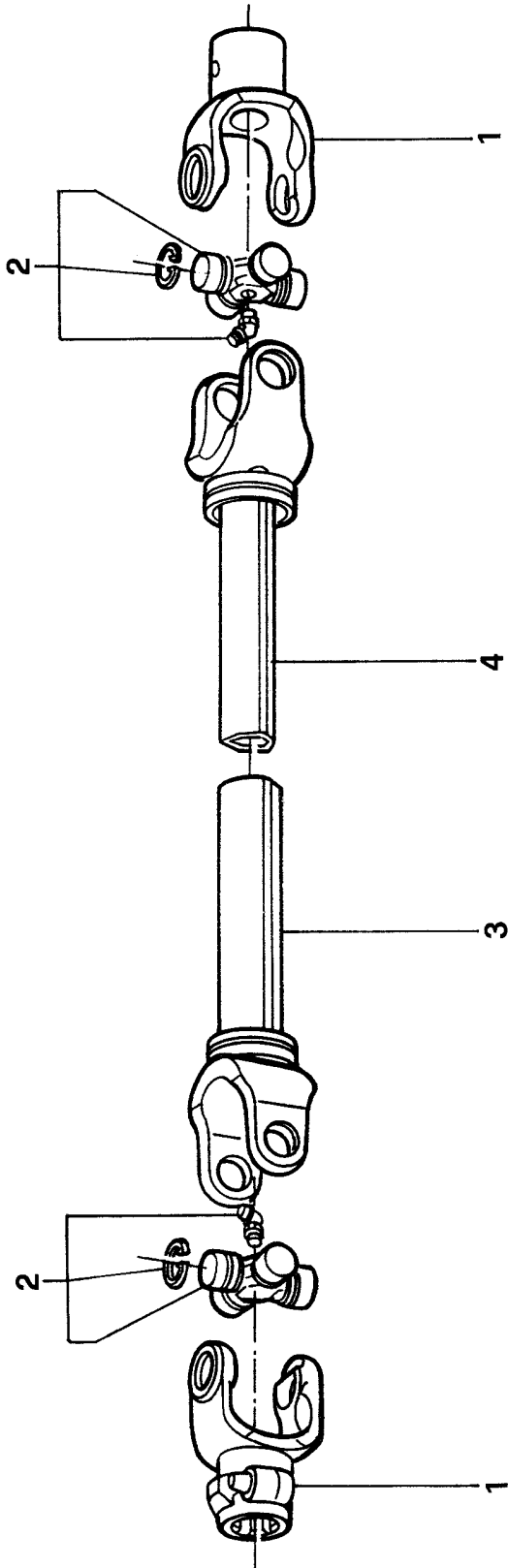

Rotomec: mod. 317 Cyclone lat.

N.	COD.	DESCRIZIONE	DESCRIPTION	DESCRIPTION	BESCHREIBUNG	N.
1	023001E	Forcella P.D.F.	PTO Yoke	Fourche P.D.F.	Aufsteckgabel	2
2	013130E	Crociera	Cross & Bearing	Croisillon	Kreuzgelenk	2
3	1943070C	Tubo esterno	Outer tube	Tube externe	Außenrohr	1
4	1953072C	Tubo interno	Inner tube	Tube interne	Innenrohr	1
5	1784210C	Anello tubo esterno	Outer tube locking ring	Anneau tube externe	Außenrohrring	1
6	1784201C	Controcuffia tubo esterno	Outer tube rigid cone	Contre coiffe tube externe	Außenrohrgegentopf	1
7	1784203C	Cuffia esterna	Outer cone	Coiffe externe	Außenschutztopf	2
8	1784212C	Spina di bloccaggio	Pin	Goupille	Haltestift	2
9	016025E	Catenella	Chain	Chaîne	Kette	2
10	1773068C	Tubo protezione esterna	Female tube shield	Tube protection femelle	Außenschutzrohr	1
11	1872068C	Tubo protezione interna	Male tube shield	Tube protection mâle	Innenschutzrohr	1
12	1784202C	Controcuffia tubo interno	Inner tube rigid cone	Contre coiffe tube interne	Innenrohrgegentopf	1
13	1784211C	Anello tubo interno	Inner tube locking ring	Anneau tube interne	Innenrohrring	1
14	9403468C	Protezione completa	Complete shielding	Protection complète	Kompletter Schutz	1
	0500439	Cardano	PTO shaft	Arbre à cardan	Kardangelenk	

Rotomec: mod. 312-315-317 Cyclone post.

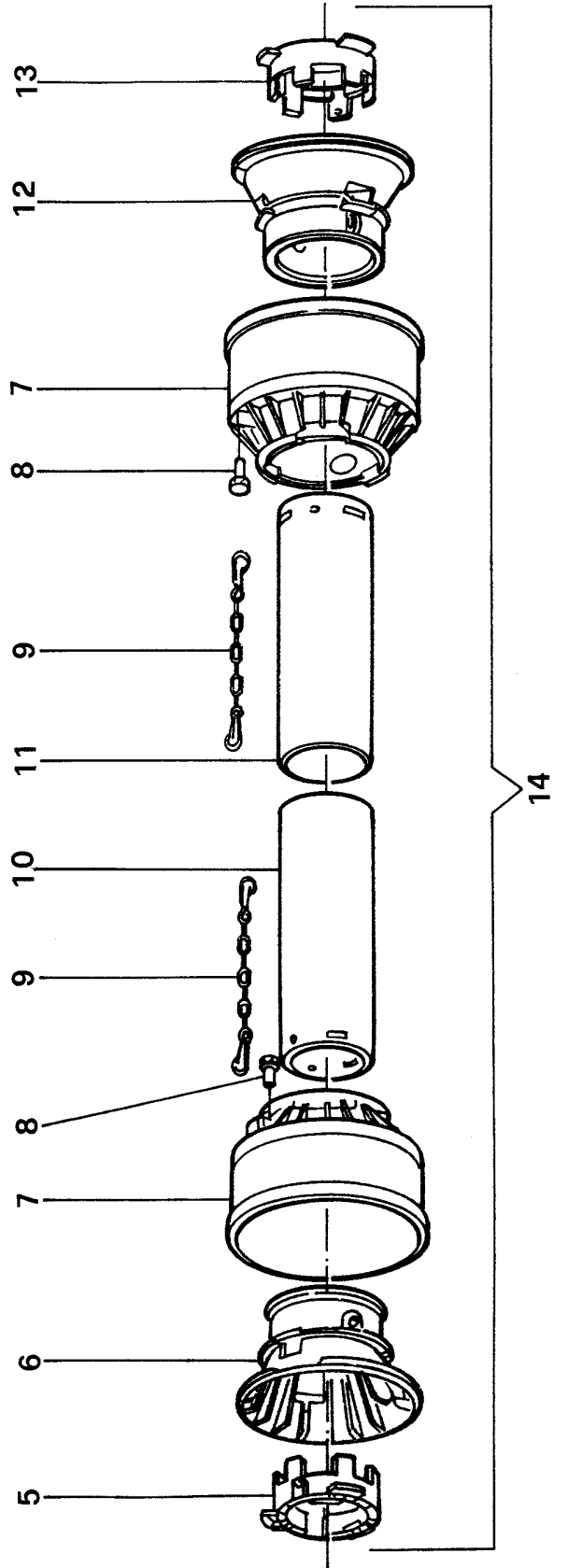
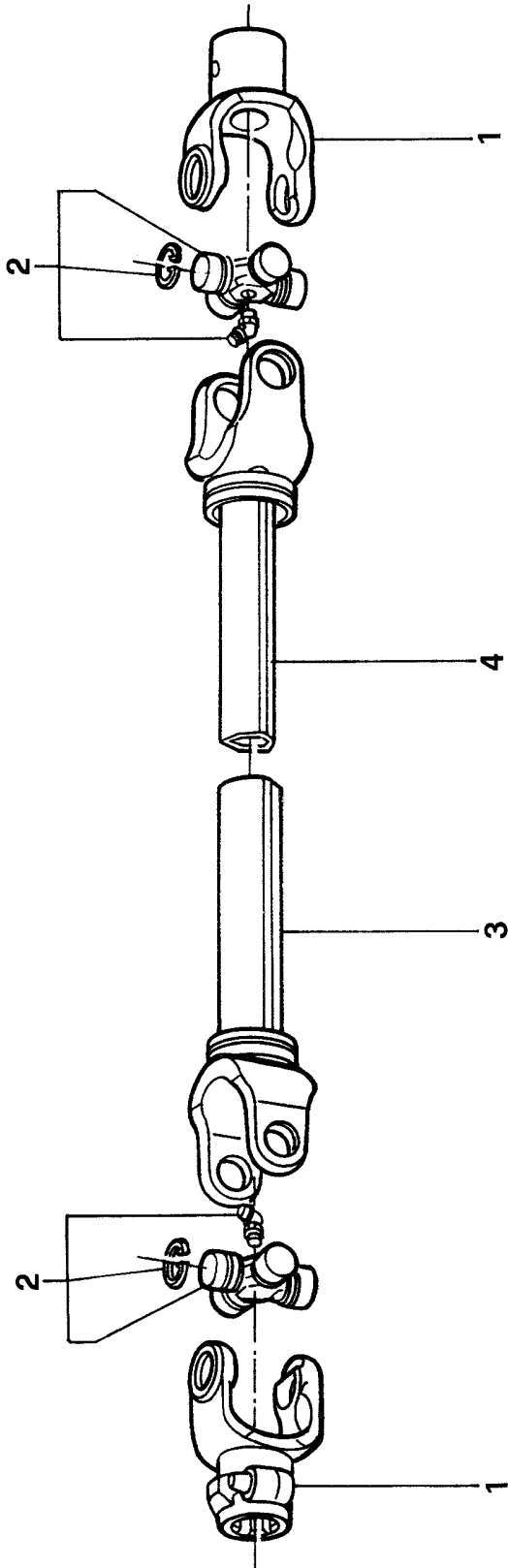

Rotomec: mod. 312-315-317 Cyclone post.

N.	COD.	DESCRIZIONE	DESCRIPTION	DESCRIPTION	BESCHREIBUNG	N.
1	023001E	Forcella P.D.F.	PTO Yoke	Fourche P.D.F.	Aufsteckgabel	2
2	013130E	Crociera	Cross & Bearing	Croisillon	Kreuzgelenk	2
3	1943070C	Tubo esterno	Outer tube	Tube externe	Außenrohr	1
4	1953072C	Tubo interno	Inner tube	Tube interne	Innenrohr	1
5	1784210C	Anello tubo esterno	Outer tube locking ring	Anneau tube externe	Außenrohrring	1
6	1784201C	Controcuffia tubo esterno	Outer tube rigid cone	Contre coiffe tube externe	Außenrohrgegentopf	1
7	1784203C	Cuffia esterna	Outer cone	Coiffe externe	Außenschutztopf	2
8	1784212C	Spina di bloccaggio	Pin	Goupille	Haltestift	2
9	016025E	Catenella	Chain	Chaîne	Kette	2
10	1773068C	Tubo protezione esterna	Female tube shield	Tube protection femelle	Außenschutzrohr	1
11	1872068C	Tubo protezione interna	Male tube shield	Tube protection mâle	Innenschutzrohr	1
12	1784202C	Controcuffia tubo interno	Inner tube rigid cone	Contre coiffe tube interne	Innenrohrgegentopf	1
13	1784211C	Anello tubo interno	Inner tube locking ring	Anneau tube interne	Innenrohrring	1
14	9403468C	Protezione completa	Complete shielding	Protection complète	Kompletter Schutz	1
	0500439	Cardano	PTO shaft	Arbre à cardan	Kardangelenk	

Rotomec: Cyclone 'Flex'

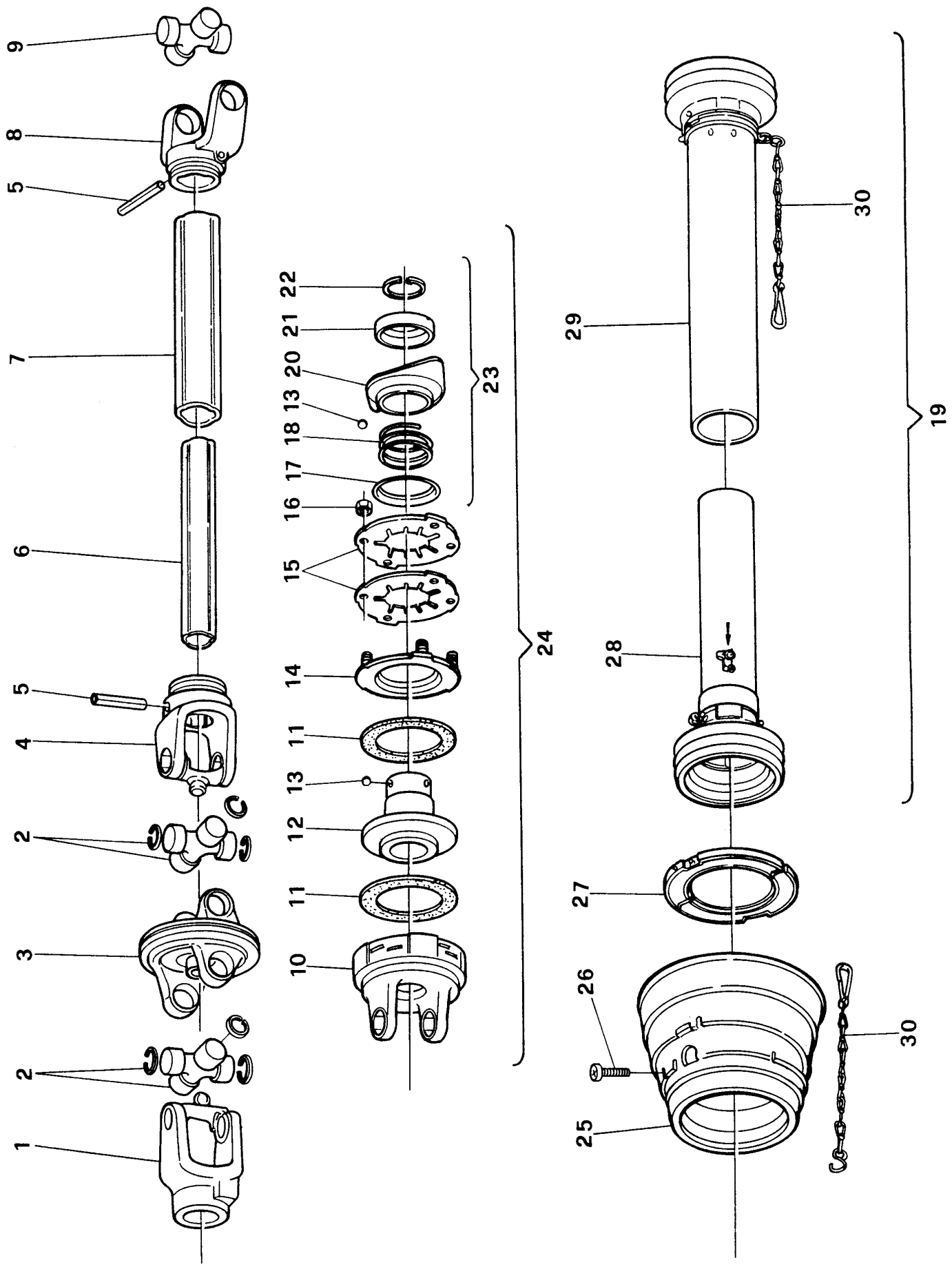

Rotomec: Cyclone 'Flex'

N.	COD.	DESCRIZIONE	DESCRIPTION	DESCRIPTION	BESCHREIBUNG	N.
1	366838W	Forcella P.D.F.	PTO Yoke	Fourche P.D.F.	Aufsteckgabel	1
2	382701W	Crociera completa	Cross & bearing	Croisillon	Kreuzgelenk	2
3	384517W	Forcella doppia	Double yoke	Double mâchoire	Doppelte Gabel	1
4	366862W	Forcella	Yoke	Fourche	Gabel	1
5	020616W	Spina elastica	Roll pin	Goupille élastique	Spannstift	1
6	046753W	Tubo interno	Inner tube	Tube interne	Innenrohr	1
7	054602W	Tubo esterno	Outer tube	Tube externe	Außenrohr	1
8	041577W	Forcella	Yoke	Fourche	Gabel	1
9	044444W	Crociera completa	Cross & Bearing	Croisillon	Kreuzgelenk	1
10	185836W	Corpo esterno	Clutch housing	Boîtier	Äußerer Körper	1
11	168556W	Ferodo	Friction disc	Disque friction	Reibscheibe	2
12	051551W	Rotore	Rotor	Rotor	Rotor	1
13	020692W	Sfera	Lock roller	Rouleau d'arrêt	Sperrrolle	6
14	381495W	Disco di pressione	Thrust plate	Disque de pression	Druckscheibe	1
15	043489W	Molla a tazza	Disc spring	Ressort à disque	Tellerfeder	2
16	381957W	Dado	Nut	Ecrou	Mutter	4
17	047825W	Anello di sostegno	Back up ring	Entretoise d'arrêt	Stützring	1
18	045793W	Molla	Spring	Ressort	Feder	1
19	106724W	Protezione completa	Complete shielding	Protection complète	Kompletter Schutz	1
20	045790W	Boccola	Bushing	Douille	Büchse	1
21	338531W	Anello sagomato	Back up ring	Entretoise d'arrêt	Geformeter Ring	1
22	304149W	Anello di chiusura	Snap ring	Circlip	Schließring	1
23	341953W	Attacco rapido	Quick disconnecting lock	Verrouillage rapide	Ziehverschluß	1
24	317189W	Frizione completa	Complete slip clutch	Embrayage complet	Komplette Kupplung	1
25	365715W	Cuffia	Protection	Coiffe	Haube	1
26	365305W	Vite	Bolt	Vis	Schraube	6
27	365717W	Anello di scorrimento	Bearing ring	Entretoise de glissement	Gleitring	1
28	185530W	Protezione esterna	Outer protection	Protection externe	Außenschutz	1
29	368508W	Protezione interna	Inner protection	Protection interne	Innenschutz	1
30	044321W	Catenella	Chain	Chaîne	Kette	2
	0500040	Cardano	PTO shaft	Arbre à cardan	Kardangelenk	